

See back cover for
new features of v1.3

INSTALLATION MANUAL

SPECIFICATIONS

Control Panel Specifications

13 zones including:

- 8 fully programmable supervised zones (EOL resistors)
- Supervised fire zone
- 1 auxiliary normally open zone
- 3 keypad activated zones

Audible alarm output:

- Bell output
700 mA, fused at 5 Amps, 12 V_{DC} unregulated
- Steady or pulsed output

EEPROM memory:

- Does not lose codes or system status on complete AC and battery failure

Programmable output:

- Transistor switch sinks 50 mA to ground
- Operation controllable through program options

Powerful 1.5 amp regulated power supply:

- 400 mA auxiliary supply, 12 V_{DC} unregulated
- Separately fused for battery, keypad/auxiliary supply and bell output
- Supervision for loss of AC power, low battery
- Internal clock locked to AC power frequency

Switched Smoke Detector Supply Output:

- Controlled from keypad [*][4] command

Battery required:

- 12 volt 4 Ah minimum rechargeable gel-cell or sealed lead-acid battery

Transformer required:

- 16.5 VAC, 40VA

Dimensions:

- 11" x 11.8" x 3.3" deep (279 x 300 x 84 mm)

Weight:

- 6.5 lbs (3 kg)

Remote Keypad Specifications (PC2550RK)

- Four wire (QUAD) hook-up and up to 3 keypads per system
- Built-in piezoelectric buzzer
- Full annunciation of zones and system status
- Nominal current draw 60 mA
- Dimensions 5.5" x 4.5" x 1" deep (140 x 114 x 25 mm)

Output Voltage Specification

Typically, with normal AC in and a fully charged battery, the output voltage will be 13.8 V_{DC}. With AC off and a discharged battery, the voltage will go to 10 volts. Devices that require power from the control panel should be capable of normal operation over the voltage range of 10 to 14 V_{DC}.

Digital Communicator Specifications

- 78 reporting codes
- Transmits all 10BPS and 20BPS single line and extended formats
- Radionics Rounds and Radionics Parity formats
- Sescoa Super fast format
- 3/1, 4/2 and hexadecimal numbers
- DTMF and Pulse dialing
- DPDT line seizure
- True dial tone detection
- Anti-jam feature
- Two telephone numbers and two account codes
- Split reporting of selected transmissions to each telephone number

FEATURES

Keypad Programming

The PC2550 comes with a default program so it is operational with a minimum of programming. It is completely programmable from the keypad. The panel uses EEPROM memory so that all information is retained even if the panel loses both AC and battery power.

Multiple Level Static/Lightning Protection

The PC2550 has been carefully designed and tested to provide reliable service. It is built to take static and lightning induced surges and keep on working. Multiple level surge filters are on all zone inputs, the power supply, the keypad connections, the bell output, the auxiliary power supply and the telephone interface. A special "ZAP-TRAC" circuit board configuration catches high voltage impulses right at the wiring terminals. Protective ground planes surround sensitive areas preventing the spread of damaging voltage surges. Metal Oxide Varistors (MOV's) are placed in all the critical areas to further reduce impulses to safe levels.

"WATCHDOG MONITOR" Circuit

Even when all precautions are taken so that voltage surges do not cause damage to the control panel, it is possible to cause temporary disruption to the operation of the microprocessor causing it to lose track of the program sequence. The PC2550 is equipped with an external "Watchdog Monitor" circuit which continually checks the microprocessor program execution.

System Supervision Features

The PC2550 continuously monitors a number of possible trouble conditions including:

- An active battery supervision circuit that periodically tests the battery under load.
- A loss of the AC power supply.
- A supervised fire circuit trouble condition.
- A telephone line monitoring circuit.
- A bell circuit failure indicates open circuit or fuse failure.
- A test code feature which transmits a communicator test code to the monitoring station at a selected time everyday. The test code can be sent at intervals from 1 to 99 days.
- A bell/siren/communicator test feature which can be activated from the keypad.
- TLM (Telephone Line Monitoring) restoral transmission.

Advanced Features

The PC2550 has many advanced features. Features which provide the security system design flexibility and selling advantage necessary to win those demanding jobs and make them profitable.

Some of these features include

- EEPROM memory retains all data even on complete AC and battery failure. Panel powers up in last armed or disarmed state before power loss.
- All programmable zones may be selected as one of 10 different types including: delay, auxiliary delay, instant, interior, interior with home-away, delay with home-away, and 4 types of 24 hour emergency and supervisory circuits.
- Keypad programming of up to sixteen security codes.
- Zone bypassing from the keypad.
- Individual zone and system function indicators on keypad.
- A keypad activated utility output function for operating lights, door openers, cameras or other devices.

Although the PC2550 has many features, it is not difficult to use. All keypad commands are similar and are assisted by audible and visual cues.

INSTALLATION

Bench Testing

The PC2550 contains a factory default program. Any additional programming required can be done through the keypad. For many applications all that will be required is to enter the telephone number and alarm codes with keypad entries that are as straight forward as dialing a telephone number. If you need help talk to your DSC equipment distributor.

Connect 1K ohm 1/2 watt end of line resistors from each zone (Z1 to Z8) input to the closest common "COM" terminal. Connect an end of line resistor between the "Fire" input terminal and the "COM" terminal between "Z1" and "Z2". Unless all zones are properly terminated with end of line resistors the "Ready" light will not be on and the panel will not arm unless the "Ready" light is on.

Connect the four keypad wires to the control panel as shown in the connection drawing.

To completely test the PC2550 including the communicator data, it is necessary to connect the panel to a digital receiver through a telephone line connection or by connecting the telephone terminals on the PC2550 to a digital communicator test set such as the DSC DTS-1. The DSC DTS-1 digital communicator test set is an inexpensive unit which can simulate the telephone system dial tone and the receiver hand shake and kiss-off tones as well as display the data sent out by a digital communicator. Also, the DTS-1 has a "listen-in" feature which makes it ideal for monitoring the transmission between communicator and receiver when the PC2550 is connected to the telephone line.

If you are using a DTS-1, connect the green and red telephone clips to the "TIP" and "RING" terminals and connect the red and black power clips to the "AUX [+]" and "AUX [-]" terminals on the PC2550. When power is applied to the panel press the red local-line button on the DTS-1 and observe the display window area. The "local-line" indicator should be in the local position.

For testing purposes, so that the sound level is not too loud, connect a small buzzer to the "BELL [+]" and "BELL [-]" terminals to indicate when the panel is in alarm.

Connect a 16.5 VAC, 40 VA transformer to the "AC" terminals. Before plugging in the transformer be sure the circuit board is not resting on anything metallic which may cause a short.

Note: The PC2550 will not start up if "AC" is off and the battery is low.

When the transformer is plugged in there should be lights on the keypad and the buzzer connected to the bell terminals may go on for a few seconds. The "Armed" light may be on or off the first time the panel is powered. The last armed/disarmed condition is stored in the EEPROM memory so the panel will always power up in the last armed/disarmed state. If the "Armed" light is on, enter the default Master Code [1234] to disarm the panel. If the keypad is not active, check for the presence of AC power at the "AC" terminals, check the keypad connections and check the panel fuses.

If all the zones are properly connected with end of line resistors all of the zone lights will be off. Note that the panel will arm only if all zones are properly connected with end of line resistors (including FIRE circuit) so that the "Ready" light is on. The keypad should beep several times to indicate acceptance of the master code. Enter the Master Code to arm or disarm the panel.

Read the "Keypad Commands" section of this manual or the Instruction Manual and enter commands on the keypad to become familiar with the different commands.

Turn to the "Programming Guide" in this manual and enter a sample program into the panel through the keypad to become familiar with the programming commands.

Mounting Panel

Select a dry location close to an unswitched AC source, a ground connection and the telephone connection.

Remove printed circuit board, mounting hardware and keypad from cardboard retainer inside panel. Before attaching cabinet to wall, press the five white nylon printed circuit board mounting studs and the ground connection screw into cabinet from the back.

Pull all cables into cabinet and prepare them for connection before mounting the circuit board to the back of the cabinet. Press circuit board down onto mounting studs.

Hook-up Procedure

DO NOT connect transformer or battery until all other wiring has been connected. See power-up procedure.

Connect a ground cable from the cabinet ground connection by the shortest and most direct route to a grounding rod.

Connect zone cables to zone inputs and put end of line resistors on any unused zones. Connect wires supplying power for motion detectors to auxiliary supply.

Install keypads and connect wires to keypad terminals on panel. Connect RJ31-X cord to telephone terminals. Do not insert plug into RJ31-X jack.

Warning: Do not use this equipment on a telephone line equipped with "call holding" feature because the tone generated may interfere with the communicator operation.

Connect bell or siren to "BELL [+]" and "BELL [-]" terminals. Observe correct polarity for sirens and polarized bells. Connect 1K ohm 1/2 watt resistor across terminals to eliminate trouble condition if bell circuit is not being used.

Terminal Connections

“AC” Power Terminals

Use a 16.5 VAC transformer with a minimum 40 VA rating to supply AC power to the PC2550. The transformer should not be connected to an outlet that is controlled by a switch. If AC failure occurs it is displayed as a trouble on the keypad (see “Keypad Functions [✱][2] Trouble Conditions”). It can also be transmitted to the monitoring station as a trouble condition (see “Programming Guide [✱][8]” sections [12] and [13] for alarm and restore codes and section [20] for AC transmission delay).

Auxiliary Power Terminals “AUX” and “GND”

The auxiliary power supply can be used to power motion detectors and other devices requiring 12 V_{DC}. 400 mA 12 V_{DC} is available from the “AUX” (positive) and “GND” (negative) terminals when the PC2550 is used with one keypad. For each additional keypad the auxiliary supply rating must be reduced by 60 mA. The auxiliary supply is fused with the keypad supply at 1 amp. Auxiliary fuse failure transmission can be sent (see [✱][8] sections [12] and [13]).

Switched Auxiliary Power Terminals “SW AUX” and “GND”

The switched auxiliary supply can be switched off momentarily from the keypad (see “Keypad Commands [✱][4]”). The “SW AUX” terminal is positive and the “GND” terminal negative. The 400 mA auxiliary supply rating must be reduced by any current taken from the switched auxiliary supply. The switched supply shares the same fuse as the auxiliary supply.

Bell/Siren Terminals “BELL [+]” and “BELL [-]”

These terminals are for powering bells or other devices requiring a steady output voltage on alarm. The bell output is fused for 5 amps. When connecting sirens (speakers with siren driver already built-in), be sure to observe the correct polarity. Connect the positive lead to the “BELL [+]” terminal and the negative lead to the “BELL [-]” terminal.

If no siren or bell is used, connect a 1000 ohm resistor between “BELL [+]” to “BELL [-]”. The bell/siren alarm output is pulsed (1 second on 1 second off) when an alarm is created by the [F] keypad zone, by the FIRE zone, or when the Bell Pulse option is enabled in section [18] light 2.

Keypad Terminals “RED”, “BLK”, “YEL” and “GRN”

Connect the four coloured wires from the keypads to these terminals. When connecting more than one keypad, connect in parallel across the keypad terminals at the control panel (i.e. all reds wires together, all blacks together, all yellows together and all greens together). The keypad red and black power supply terminals are fused through the auxiliary fuse.

Programmable Output Terminal “PGM OUT”

The operation of the Programmable Output depends upon which option is selected in the programming table. See the “Programming Guide” section [30] for a list of options for the “PGM OUT” output. The “PGM OUT” is a 50 mA maximum

switch to ground. A 100 ohm current limiting resistor is connected in series. A small relay, a buzzer or other DC operated device may be connected between the 12 V_{DC} “AUX” (positive) terminal and the “PGM OUT” (switched negative) terminal on the main board.

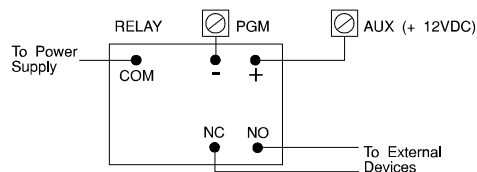

Auxiliary Input Terminal “AUX IN” (also KEY ARMING)

The “AUX IN” input terminal is a normally open 24 hour zone. It can be programmed from the keypad to be silent or audible. There is no display on the keypad for the “AUX IN” input. An alarm on this input is created by applying a positive voltage or by closing a contact between the “AUX IN” terminal and the positive auxiliary supply. See “Programming Guide [✱] [8]” section [11] for programming the alarm and restoral codes.

The “AUX IN” terminal can also be used as a momentary key arming/disarming input. See “Programming Guide” section [30] for a list of options for the “AUX IN” terminal.

“FIRE” Zone Input

The “FIRE” zone is a supervised (normally open alarm initiating contact) end-of-line resistor circuit designed to accept “Latching” four-wire smoke detectors. (See “Fire Circuit Installation Diagram”.)

On alarm, (fire zone shorted) the bell output will pulse the signal to indicate that the fire zone has been activated. Alarm memory and transmission by the digital communicator is delayed 30 seconds. If the alarm is acknowledged, by pressing the [#] key before the 30 second delay has expired the signals will silence and the transmission will be aborted. If the alarm is not acknowledged and the 30 second delay expires, the fire memory latches and the transmission cannot be aborted.

If after signal silence, the smoke detector is not restored to normal, the signals will resound after 90 seconds, and 30 seconds after that, the communicator will transmit. If the signals resound, they may again be silenced, [#] key, and the communicator will be aborted if silence occurs within the 30 second delay period.

To restore the smoke detector to normal, clear all products of combustion from the detector and reset the detector by pressing [✱] and then holding down [4] for 2 or 3 seconds. This action will remove power from the smoke detector and if it is clear of smoke, the detector will return to normal. If the detector is still in alarm, the signals will sound immediately and the above sequence will repeat.

For an open on the FIRE zone, the keypad sounder will beep twice every 10 seconds and the “Trouble” light will show on the keypad. The communicator will transmit the trouble condition if programmed for trouble transmission. The audible trouble signal may be silenced by pressing the [#] key. To determine the nature of the trouble, press [✱][2] (See the “Trouble Display” section).

Zone Input Terminals “Z1” to “Z8”

Zone inputs “Z1” to “Z8” are supervised end of line (E.O.L.) resistor circuits. Each input must be terminated with a 1K ohm E.O.L. resistor. An alarm condition will be created if a normally open contact is used to short across the E.O.L. resistor. An alarm is also created if normally closed contacts, wired in series with the E.O.L. resistor, are opened. See the wiring diagram for normally open and normally closed contact connection. The type of circuit or zone definition (delay, instant, 24 hour etc.) is programmed from the keypad using the [*][8] Installer’s Programming commands (“Programming Guide” section [14]).

Telephone Terminals “TIP”, “RNG”, “T-1” and “R-1”

The wires from the RJ31-X telephone jack are connected to these terminals in the following way.

TIP	Green wire	▶	<i>Incoming line from telephone company</i>
RNG	Red wire		
T-1	Brown wire	▶	<i>Outgoing line to house telephone(s)</i>
R-1	Grey wire		

Note: For proper operation there must be no other telephone equipment connected between the control panel and the telephone company’s facilities.

Battery Connections

Do not connect the battery or the transformer until the wiring is complete. Connect the red battery lead to the positive battery terminal and the black lead to the negative battery terminal. If the connection is made in the reverse the battery fuse will fail.

Keypad Installation

Mount the keypads near the exit-entry doors. The PC2550RK keypad has a red, a black, a green and a yellow wire on the back. Connect these four wires to the four keypad terminals on the control panel using four conductor (quad) telephone wire. Up to three keypads may be connected to one PC2550. Connect all green wires from the keypads to the “GRN” terminal on the panel. Connect all yellow wires from the keypads to the “YEL” terminal on the panel. Connect all red wires from the keypads to the “RED” terminal. Connect all black wires from the keypads to the “BLK” terminal.

Power-up Procedure

If the keypads are located a distance from the panel, install an extra keypad temporarily at the panel during power up testing. An extra keypad with a short length of cable and alligator clips attached is helpful for testing and programming PC2550 systems.

Connect the transformer, wait approx. 5 seconds.

Enter a few keypad commands and open a zone to be sure that the panel and keypad are responding to signals. If the keypad does not respond and there are no indicators on, check for AC voltage at the “AC” terminals. If there is 16 VAC present, check that the keypad wiring is correct and check the keypad/auxiliary supply fuse. If the keypad/auxiliary supply fuse is blown check for a short between the keypad red and black wires before replacing the fuse.

If the keypad is responding normally, connect the battery. The red battery lead attaches to the positive battery post and the black battery lead attaches to the negative battery post.

Note: The PC2550 will not start up if “AC” is off and the battery is low.

Testing The System

See Installer’s test - [*] [6] [Master Code] [0] (page 9), or do the following. Contact the monitoring station to request a transmission test. Plug the telephone cord into the RJ31-X jack. If a DTS-1 is being used to monitor communicator transmissions, connect as described in “Bench Testing” section and place the DTS-1 in the line mode by pressing the red “LINE/LOCAL” button. Arm the panel, wait for the exit delay to expire and trip a detector on an instant circuit. Wait for the communication to complete. Disarm panel and check with the monitoring station to confirm the transmission. Perform additional transmissions required by the monitoring station.

Check the “Trouble” light on the keypad. If it is on, press [*] then [2] to determine if there is a system trouble. The “Trouble Display” section in “Keypad Commands” gives a description of the different trouble conditions.

Instructing End-User

Fill out the system reference guide in the PC2550 Instruction Manual. Check off sections in the manual which apply to the user’s system and make additional notes if necessary.

Describe the system to an authorized user. Describe arming and disarming procedures. Describe the basic keypad functions. Assist the user in working through examples of each type of command.

Provide user(s) with the Instruction Manual and instruct them to read the manual to become familiar with the system operation.

Instruct the user to test the system on a regular basis as described in the Instruction Manual. The Master Code should be changed from the default setting and recorded in the Instruction Manual.

GUIDELINES FOR SMOKE DETECTOR LOCATION

Experience has shown that all hostile fires in family living units generate smoke to a greater or lesser extent. Experiments using typical fires in family living units indicate that detectable quantities of smoke precede detectable levels of heat in most cases. For these reasons, smoke detectors should be installed outside of each sleeping area and on each additional story of the family unit.

The following information is for general guidance only and it is recommended that the smoke detector manufacturer's literature be used for detailed installation instructions.

It is recommended that additional smoke detectors beyond those required be installed for increased protection. The added areas include: basement, bedrooms, dining rooms, furnace room, utility room and hallways not protected by the required detectors.

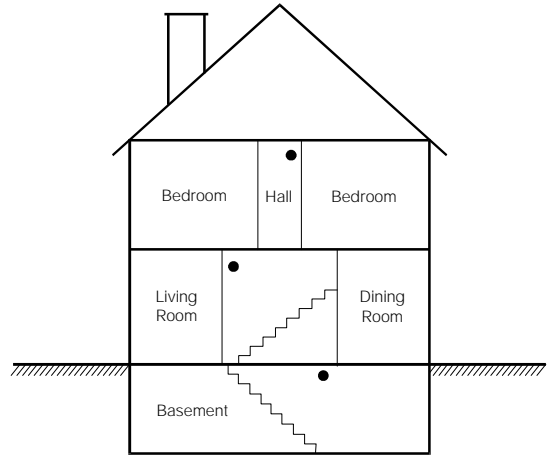

FIG. 3: A smoke detector should be located on each story of the living unit.

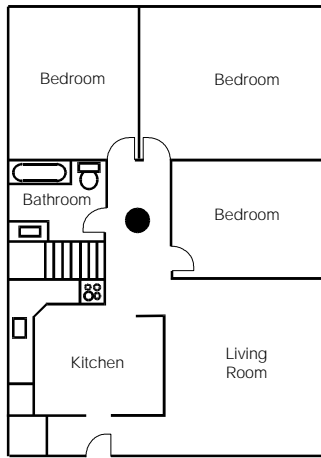

FIG. 1: A smoke detector should be located between the sleeping area and the rest of the family unit.

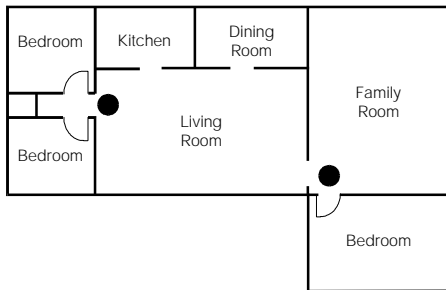

FIG. 2: In the family living units with more than one sleeping area, a smoke detector should be located to protect each sleeping area.

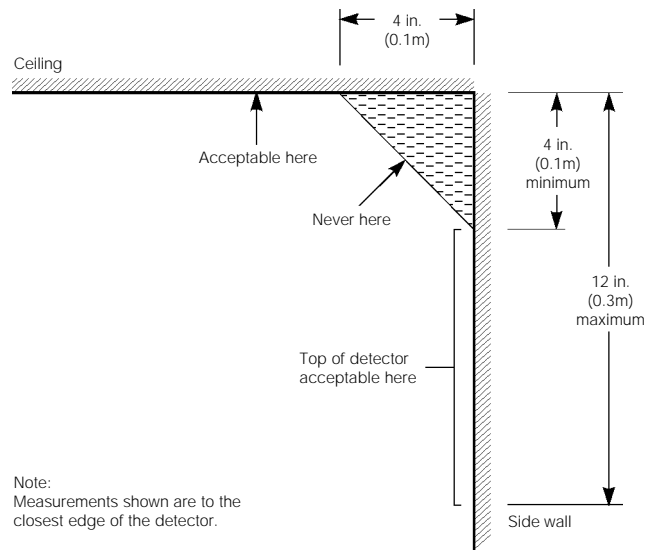

FIG. 4: Smoke Detector mounting - "Dead" Air Space. The smoke from a fire generally rises to the ceiling, spreads out across the ceiling surface and begins to bank down from the ceiling. The corner where the ceiling and wall meet is an air space into which the smoke may have difficulty penetrating. In most fires, this "dead" air space measures about 4 in. (0.1m) along the ceiling from the corner and about 4 in. (0.1m) down the wall as shown in Figure 4. Detectors should not be placed in the dead air space.

KEYPAD FUNCTIONS

Introduction

The PC2550RK remote keypad provides complete information and control of the PC2550 control panel. The panel can be fully programmed from the keypad. The 8 zone lights and the fire alarm light provide alarm and status indication for the alarm circuits. The 6 function lights guide the user in operating the system. The built-in buzzer lets the user hear correct key entries and other alert signals. The 12 digit keypad is used for code entry and other programming functions. All keypad entries are made by pressing one key at a time.

The keypad is normally resting in the arm-disarm mode. In this condition the zone lights are indicating the opening and closing of zones. The "Ready" light comes on when all zones are closed. The system can be directed to perform other functions such as zone bypassing, displaying trouble conditions, displaying alarm memory and programming by entering one of the various [*] commands described below. Pressing the [#] key or not making any key entry for 2 minutes always returns the keypad to the arm-disarm mode.

Master Code

A default Master Security Code "1234" is programmed into the PC2550 at the factory. The Master Security Code is used for arming and disarming the control panel, for programming up to fifteen additional security codes using the [*][5] command and for entering other user functions using the [*][6] command. The Master Code can be reprogrammed if the installer leaves section [16] light 2 off. Because the PC2550 uses EEPROM memory the codes and other data are retained even after complete AC and battery failure.

2nd Master Code

A second master security code "xxxx" can be programmed into the PC2550. This code can be changed by the installer only, and is useful where there are multiple panels in a complex. The 2nd Master Code can be used as a "Master Key". The default 2nd Master Code is blank.

Installer's Programming Code

A default Installer's Programming Code "2550" is programmed into the PC2550. This code is used with the [*][8] command by the installer to gain access to the system in order to enter panel or communicator program information. The Installer's Programming Code may be changed by the installer.

Arming

Check to see if the "Trouble" or "Bypass" light is on before arming the PC2550. Close all protected doors and windows and stop movement in areas covered by motion detectors. Check to see that the "Ready" light is on (all zones are closed). The system cannot be armed unless the "Ready" light is on. Enter a [4 Digit Security Code]. As each digit is entered the keypad buzzer will beep. If the security code was entered incorrectly, the sounder will beep steadily for 2 seconds. If the code was entered correctly but the "Ready" light was not on, the keypad will beep quickly followed by a steady tone. When the correct code is entered, the "Armed" light will come on and the keypad buzzer will beep quickly. Exit the premises through the designated exit-entry door. At the end of the allowed exit time all lights on the keypad will go out except the "Armed" light. See the "Installer's

Programming [*][8] Command" section for instructions on how to change the exit time. Also see, "Quick Arm" and "At Home Arming".

Disarming

Enter the premises through the designated exit-entry door. The keypad buzzer will be on. Go to the keypad and enter the [4 digit security code]. If an error is made in entering the code, press the [#] key and enter the code again. The "Armed" light will go out and the keypad sounder will stop. The correct security code must be entered before the allowed entry time expires. To change the entry time see "Installer's Programming Command", [*][8]. If an alarm occurred while the panel was armed, the "Memory" light and the "Zone" light which caused the alarm will start to flash and stay flashing for 2 minutes when the panel is disarmed. Pressing the [#] key returns the panel to the normal arm-disarm mode.

Auto-bypass/Home-Away Arming

If a correct security code is entered, and you do not exit the premises, the system will, at the end of the Exit delay time, arm with interior zones automatically bypassed if those interior zones have been programmed as "Home-Away" zones. The "Bypass" light will come on immediately following the arming code being entered until a delay zone is tripped or [*][1] is entered to reactivate bypassed home-away zones. (See programming section [14], zone definitions for programming zones as "Home-Away".)

This is a convenience feature for the user who wishes to remain at home with the system armed. The user does not have to manually bypass the home-away zones.

To reactivate the home-away zones that have been automatically bypassed, press [*][1]. The "Bypass" light will go out. This command is a quick method of fully arming the system before going to bed.

Zone Bypassing

[*][1] or [*][1]+[Access Code]

A bypassed zone will not cause an alarm. If a zone is bypassed the panel may be armed ("Ready" light will be on) even if the zone is open. Use zone bypassing when access is needed to part of the protected area. Also, damaged wiring or contacts on a zone may be temporarily bypassed until repairs can be made so that the panel can be armed.

If section [18] light 3 is on, all bypassed zones will be shown when armed. Home-Away zones that are automatically bypassed will show as well. This feature cannot be used with a split armed system. If section [17] light 8 is on then the bypass status will always be shown.

To bypass zones, enter [*][1] and the zone number(s) to be bypassed. Press [#] to return to "Ready" (arm-disarm mode). To remove all bypasses, enter [*][1][0][#]. The "Zone" lights which are on, while the "Bypass" light is flashing, indicate the bypassed zones. Remember that if no keypad entry is made for more than 2 minutes the keypad will return to the arm-disarm mode. Then, in order to bypass a zone the complete command must be re-entered. Once the bypass command is entered, pressing [9] recalls the last

zone or group of zones which was bypassed. If the same group of zones is bypassed each time, this bypass recall feature can be used instead of having to bypass zones individually.

When the PC2550 is programmed, the ability to bypass certain zones may be eliminated. In this case, the "Zone" lights for those zones will not come on in response to the bypass command. See the "Zone Bypass Mask" instruction in the [*][8] Installer's programming section. If the "Bypass" light is on when arming the panel, the [*][1] command should be used to see which zones are bypassed so that zones are not unintentionally bypassed. Zone bypasses are automatically cancelled when the panel is disarmed.

If light 8 in section [16] is on then a code must be entered with [*]+[1] to bypass zones. Only the zones assigned to the same side of the system as the user code can be bypassed. The ability to bypass using certain access codes can be eliminated. See the "Access Bypass Mask" instruction in the [*] [8] Installer's Programming section.

Note: At no time can any armed zone be bypassed.

Trouble Display

[*]+[2]

The PC2550 continuously monitors a number of possible trouble conditions. If one of these conditions occurs, the keypad "Trouble" indicator will light and the audible indication will sound (two short beeps every 10 seconds). When the [#] key is pressed the audible indication will stop but the "Trouble" indicator light will remain on until the trouble is cleared. Trouble conditions can also be transmitted to the monitoring station (see "Programming Guide" sections [12] and [13] for alarm and restoral trouble codes). Press the [*] then [2] keys to display the type of trouble. The "Zone" lights indicate the type of trouble condition.

- 1 Low stand-by battery
- 2 AC power failure
- 3 Day zone trouble
- 4 Telephone line trouble
- 5 Fail to communicate
- 6 Bell circuit failure
- 7 Fire alarm circuit trouble
- 8 Loss of time on internal clock

Press [#] to return to "Ready".

1 Low Battery...A battery trouble will be displayed and can be reported if the battery is weak, disconnected or the battery fuse is blown. Only one low battery alarm or restoral transmission takes place per arming period. Low battery trouble display is latching and can only be cleared by battery restoration, and arming and disarming the panel.

2 AC Power Failure...There is no audible annunciation on AC power failure. The system "Trouble" light will come on but the audible indication will not sound until there is a low battery condition. Transmission delay can be programmed for 1 to 99 minutes. See "Programming Guide" section [20].

3 Day Zone Trouble...This trouble applies only to zones which have been programmed as day zones. ("Programming Guide" section [14]). A day zone creates a trouble signal when the panel is disarmed and an alarm signal when the panel is armed.

4 Telephone Line Trouble...A telephone line trouble is generated when the line voltage drops below 3 volts for more than 30 seconds. It generates a keypad trouble when the system is disarmed and rings a local alarm when the panel is armed. See section [16] for options.

5 Fail to Communicate...If the digital communicator is unsuccessful communicating with the monitoring station after eight attempts to each phone number that is to be tried, a trouble is generated. If a later attempt to communicate is successful the trouble is cleared. Also the trouble will be cleared when the trouble display is viewed and exited.

6 Bell Circuit Failure...If the bell fuse fails or the bell circuit is open, a keypad trouble and a trouble transmission are generated.

7 Fire Alarm Circuit Trouble...If a FIRE zone is open circuit, a keypad trouble and a trouble transmission are generated. A trouble on the FIRE zone will unconditionally initiate an audible indication on the keypad. This means that even if any other previous trouble has been silenced, a FIRE zone trouble will restart the keypad buzzer.

8 Loss of Internal Time...When the PC2550 is powered up or reset, the internal time of day clock needs to be set to the correct time. This trouble is cleared when the trouble display is viewed and exited or when an attempt is made to reset the internal time of day clock. See "[*][6] User's Function Command" for resetting time of day clock.

If the [9] is pressed while in the trouble display mode the most recent trouble will be displayed on the zone LEDs. This trouble memory feature is useful as a diagnostic aid when installing and servicing the PC2550.

Alarm Memory Display

[*]+[3]

Press [*] then [3] to enter the alarm memory mode. The "Memory" light will flash and any alarm caused during the last armed period will be displayed on the zone lights. In addition to the last alarm memory there are 2 history levels. After entering the memory mode (pressing [*] then [3]), pressing [9] will cause the keypad to display the two other levels of alarm history. Each time [9] is pressed the keypad will beep 1, 2 or 3 times to indicate which level of history is being viewed. When the panel is armed, the last alarm memory is cleared and the contents moves to the 1st history level. The "Memory" light will only be on when there was an alarm during the last armed period.

Press [#] to return to "Ready".

Switched Auxiliary Supply Control

[*]+[Hold Down 4]

To interrupt the switched auxiliary power supply press [*] then hold down [4] for the desired interrupt time. When the [4] is released the system returns to the ready mode and the switched auxiliary supply is restored.

User's Programming Commands

[*]+[5]+[MASTER CODE]

The [*][5] user's programming commands are used to program additional access codes. Up to 16 user arm-disarm codes may be programmed. The 1st code is the Master Code (factory default [1234]). The 16th code is optionally a "One Time Use" or maid code. The 16th code may be changed from a "One Time Use" code to a regular code using an installer's programming command (section [15]...light 8). Remember if no keypad entry is made for more than 2 minutes the keypad will return to the normal arm-disarm display and the complete command will have to be re-entered to program a new access code.

Programming Additional Access Codes

1 Press the [*] and [5] keys then enter the Master Security Code (default [1234]) to enter the additional code programming mode. The "Program" light and "Zone 1" light will be on to show that the first code (the Master Code) is already programmed with the factory default code [1234]. The Master Code may be changed but do not try to erase the Master Code. The installer can disable user changing of the Master Code by turning on light 2 in section [16].

2 15 additional codes may be programmed. The zone lights are used to indicate which of these codes are already programmed (zone light on steady) and the one which is currently being programmed (zone light is flashing).

3 To program the second code, press [2] and zone 2 light will flash. Then enter a 4 digit code and the buzzer will beep three times and zone light 2 will come on steady indicating a programmed code.

4 To remove the second code, press [2] - the buzzer will beep three times and zone light 2 will flash. Enter [*][*][*][*], the buzzer will beep three times and zone 2 light will go out to show that the code has been removed.

5 Follow the instructions in **3** or **4** for programming or removing any of the other additional codes.

6 To program access codes 9 to 16, press 9 to toggle into the upper code region. Zone lights 1 to 8 now represent access codes 9 to 16 (light 1 is code 9.... light 8 is code 16). The "Ready" and "Armed" LEDs will flash to indicate that the user is in the upper programming region. Program or remove access codes 9 to 16 as stated in 3 and 4 above. Press 9 again to toggle back down to the lower region (access codes 1 to 8).

7 Do not try to remove the Master Code (1st code). The Master Code may be changed but it must not be removed. When changing the Master Code be sure to enter a valid 4 digit number (use only number keys 0 to 9). Do not enter [#] or [*] as one of the digits. If the Master Code is forgotten and the panel is left disarmed, program a new Master Code using the [*][8][Installer's Code][25] command. If the Master

Code is forgotten and the panel is left armed, use the 2nd Master Code to disarm the system. If the 2nd Master Code is not programmed then the entire programming can be reset to factory default by using the "Hardware Reset" method described on page 24.

8 To successfully program or remove additional codes, the panel must be put into the code program mode by following step 1 followed by steps 3 or 4. Note that if no key entry is made for 2 minutes the panel will go back to the normal arm/disarm mode, after which step 1 must be repeated to get back into the code program mode.

9 To exit the code program mode press [#].

To review:

programming a new code;

enter [*] [5] [Master Code] [1 to 8] [4 digit code], or
[*] [5] [Master Code] [9] [1 to 8] [4 digit code]

eliminating an existing code;

enter [*] [5] [Master Code] [2 to 8] [****], or
[*] [5] [Master Code] [9] [1 to 8] [****].

Note: The access code numbers must be entered as one digit. E.g. 2, 3,....., 7, 8.

User's Functions Command

[*]+[6]+[MASTER CODE]

This command is used to set the system clock time and to set the auto-arm time. It is also used to turn on and off a number of system functions. The command is used by entering [*], [6], [Master Code] then a number from the following list to select the item to be changed.

[0] Installer's test

[1] System 24 hour clock (enter HH:MM)

[2] Auto-arming time (enter HH:MM)

[3] DO NOT USE

[4] Quick arm enable/disable

[5] Auto-arm enable/disable

[6] Door chime enable/disable

[7] DO NOT USE

[8] Bell test function

[9] User Initiated Callup

Note: The system clock is a 24 hour clock and times must be entered as two digit numbers.

e.g. HH - 00, 01,.....10,11,.....22, 23

MM - 00, 01,.....35,36,.....58, 59

[1] and **[2]** are time setting functions.

Enter 4 digits representing the time in hours and minutes (HH:MM) based on the 24 hour or military clock. Always enter a leading zero where only 1 digit is required, i.e. 8:05 am would be entered as 0805 and 1:30 pm would be entered as 1330.

[0], **[4]**, **[5]** and **[6]** turn on and off various features. When the option key is pressed, the feature is turned on if the keypad beeps quickly 3 times. The feature is turned off if the keypad sounds one long beep.

[8] gives a 2 second bell and keypad light test.

[9] makes the panel call the Downloading computer if enabled in section [47].

Installer's Test

[*]+[6]+[MASTER CODE]+[0]

This feature is designed to assist the installer in testing the system. In this mode, the bell or siren will operate for 2 seconds each time a device is tripped and the first level of memory will be affected. The feature is automatically disabled when the panel is armed and disarmed. Each time a zone is tripped or restored in this mode, a signal, if programmed, will be transmitted to the monitoring station. If this is not desired, it is possible to disable the communicator during the test (see section [15] "1st System Option Code").

Notes: Do not use the PC16OUT module during the installer's test.

Do not use the installer's test when the panel is partially armed.

Setting the Clock

[*]+[6]+[MASTER CODE]+[1]

Setting the "System 24 Hour Clock" (item [1]) tells the system the correct time of day. If the system is without battery and AC power it cannot continue to keep time. Therefore when the panel is first powered up or when it has been without AC power long enough to completely discharge the stand-by battery, the "System 24 Hour Clock" must be reset. If the time needs to be reset a "Trouble #8" will be indicated on the keypad (see [*][2] "System Trouble Command").

Auto-arm Time of Day

[*]+[6]+[MASTER CODE]+[2]

The PC2550 can be programmed to arm at the same time each day. Programming item [2] sets this time and the feature must be enabled as shown in item [5] (see "Auto-arm Enable" on this page).

At the selected auto-arm time the keypad beeper begins to sound and the Bell/Siren will pulse once every 10 seconds to alert anyone on the premises that the system is about to arm. The Bell/Siren pulse can be silenced in section [17] by turning light 1 on.

The keypad beeper will sound for one minute before auto-arming unless one of the following two methods is used to abort the auto-arm.

- **Auto-arm cancel:** Any key can be pressed to cancel the auto-arm sequence and silence the keypad during the one minute pre-alert (this is the default condition).
- **Auto-arm cancel with code:** If section [17] light 4 is on, then a valid 4 digit access code is required to cancel the auto-arm sequence.

The auto-arm will be attempted at the same time the following day. Any time an auto-arm is cancelled using one of the above methods, the reporting code programmed in section [08] will be transmitted to the central station.

When the panel does arm by auto-arming, any open zones will be "Force-armed". If light 5 in section [18] is on, the panel will send a partial closing code to let the central station know zones were bypassed. If section [16] light 1 is on, the zones that were force-armed will be identified by transmitting their alarm code along with the partial closing code.

Quick Arm

[*]+[6]+[MASTER CODE]+[4]

The "Quick Arm" feature is enabled by pressing the [4] key while in the "User Functions Command" section. When enabled (enabled 3 beeps....disabled one long beep) the panel can be armed by entering [*][0]. The closing code transmitted for "Quick Arm" is the same as the code which is programmed for the Master Code.

Auto-arm Enable

[*]+[6]+[MASTER CODE]+[5]

Entering [*] [6] [Master Code] [5] will enable/disable the Auto-arming feature. When the feature is being Enabled, the keypad buzzer will sound 3 beeps and when being Disabled the buzzer will sound one long beep.

Door Chime

[*]+[6]+[MASTER CODE]+[6]

The "Door Chime" feature is enabled by pressing the [6] key while in the "User's Functions Command" section. When enabled the keypad buzzer will beep quickly 5 times each time any zone defined as a delay or instant circuit opens or closes. The "Door Chime" feature does not operate on other zone definitions. Zone bypass may be used to eliminate "beeping" on doors where it is not wanted. This feature operates only while the panel is disarmed.

System Test

[*]+[6]+[MASTER CODE]+[8]

The system test feature sounds the bell or siren, lights the keypad indicators and beeps the keypad buzzer for 2 seconds. If a code is programmed in section [50] it will be transmitted at the same time.

User Callup

[*]+[6]+[MASTER CODE]+[9]

This function is enabled in section [47]. When activated, the panel will call the downloading computer. The downloading computer must be waiting for the panel to call before downloading can be performed.

Utility Output Command

[*]+[7] OR [*]+[7]+[ACCESS CODE]

The programmable output (PGM terminal) on the PC2550 can be made to activate by a command from the keypad. This output can be used for operating other devices such as garage door opener, special lighting or door strikes.

The programmable output must be selected for keypad utility using the [*][8][Installer's Code][30] command and programming a [2], [3], [4] or [5].

Depending on the option chosen in the programming section, the programmable output is activated by pressing the [*] then [7] keys followed by a Group A access code, Group B access code, any access code, or no code at all. When the proper keys are pressed the keypad sounder and the programmable output are activated for 5 seconds.

Installer's Programming Commands

[*]+[8]+[INSTALLER'S CODE]

The PC2550 is completely programmed from the keypad by using commands in the [*] [8] section. The commands are described in detail in the programming section of this manual.

"At Home" Arming

[*]+[9]+[ACCESS CODE]

Entering [*], [9] before the arming code, arms the panel without any entry delay on the delay zones and bypasses zones that are defined as "Home-Away". This command is used for arming the system while at home. When the panel is armed using [*], [9], the "Armed" light will be on flashing and the bypass light will be on to indicate that the "Home-Away" zones are bypassed. Once the panel is Armed in this mode, using [*], [1] will remove the bypass from those zones defined as "Home-Away" if they have **NOT** been manually bypassed. The [*], [1] command used here, only removes the bypass from zones that have been Automatically bypassed with the [*], [9] command."

"Quick Arm" Command

[*]+[0]

Entering [*][0] is accepted as a valid arming code when the "Quick Arm" feature is activated. Quick Arm may be used as a convenience for regular users or when the system is to be armed by individuals who are not authorized to disarm the system. See instructions in the "[*][6] User's Functions

Command" section for activating the "Quick Arm" feature. This feature should not be enabled if the One Time Use Code is enabled. The One Time Use Code must be used for arming before it is erased.

Quick Exit

[*]+[0] When Armed

Entering [*] [0] when the system is fully armed will allow the user 2 minutes to exit the premises through any delay zone without altering the status of the system if the Quick Exit feature is enabled. The Quick Exit feature can be enabled by turning on light 1 in section [18]. After [*] [0] is entered into an armed system, one and only one delay zone may be tripped. Any additional activity on any other active zone will cause that zone to begin its alarm sequence.

[*] [0] for Quick Exit on a partially armed system is not supported.

Quick Exit is not designed to extend the standard Exit Delay. It must not be used when auxiliary delay zones are force armed. Turn light 6 in section [17] off to ensure proper operation.

Keypad Zones

There are three zones which can be activated from the keypad. The alarm and restoral codes for keypad zones are programmed using the [*][8] command.

Pressing the [F] key or the [1] and [3] keys for 2 seconds activates a Fire alarm. The fire alarm sounds the siren/bell in a pulsed mode and is annunciated as a memory condition. The Fire key can be turned off in section [18].

Pressing the [A] key or the [4] and [6] keys for 2 seconds activates an Auxiliary keypad zone. If a reporting attempt is made to an alarm receiver and it is successful the PC2550 will acknowledge the transmission with a short series of beeps from the keypad.

Pressing the [P] key or the [*] and [#] keys for 2 seconds activates the Police (or Panic) alarm. The panic alarm can be programmed for audible or silent operation (see sections [15] and [18] in "Programming Guide").

There is no light annunciation from the keypad for the last two keypad zones, however, the keypad buzzer beeps 3 times to confirm activation on any of the keypad zones.

See section [11] for alarm and restoral codes for all three keypad zones.

DOWNLOADING

The PC2550 supports the DSC "downloading" package. See the downloading manual for details on specific capabilities.

There are several sections pertaining to the downloading feature which must be programmed.

Section [27] - Downloading Access Code

A four digit code must be programmed into this section to allow access to the control panel by the downloading computer.

Section [28] - Panel Identification Code

A four digit code must be programmed into this section to allow the downloading computer to identify the panel it is communicating with.

Section [46] - Downloading Computer Telephone Number

If Callback is enabled, section [47] zone light [8], then this section must be programmed with the telephone number of the downloading computer.

Section [47] - Modem Configuration

Zone lights [1] to [4] are programmed to set the number of rings the panel will look for before it answers a call from the downloading computer.

Zone light [5] is programmed to enable or disable the control panel for downloading. If downloading is disabled, all other programming sections relating to downloading need not be programmed.

Zone light [6] enables or disables user initiated callup to the downloading computer.

Zone light [7] enables or disables the answering machine defeat option (Answering Machine Over-ride).

Downloading and Answering Machine

The PC2550 software provides a means to handle downloading when an answering machine is also connected to the telephone line. In section [47], if zone light 7 is off, it is assumed that there is no answering machine connected to the telephone line and the panel will capture the line after the set number of rings.

If zone light 7 is off and an answering machine is connected and it is set to answer before the panel, the panel will be unable to receive a call from a downloading computer. If the panel is set to answer before the answering machine, the answering machine will be unable to receive incoming messages.

If zone light 7 is on and the panel is called for 1 or 2 rings only and then called again within a set time of 1 to 249 seconds (set in section [49]), the panel will then answer the second call on the first ring (Answering Machine Over-ride Timer).

Once the panel is connected to a downloading computer, no **[*]** functions can be performed. If the **[*]** key is pressed while the panel is connected to a downloading computer, the keypad buzzer will sound one long tone to indicate an error.

Zone light [8] is programmed to enable or disable callback. If callback is disabled, the downloading computer will have immediate access to the control panel. The disabled mode is useful if there are multiple downloading computers (at different telephone numbers). If callback is enabled the downloading computer will call, request access then hang up and wait for the control panel to call. After the control panel has called back and the downloading computer and the control panel accept each other as valid, downloading operations are enabled.

Section [48] - Test Transmission and/or Periodic Download Enabled

Zone light [7] programs the enable or disable of test transmission.

Zone light [8] programs the enable or disable of periodic download.

Section [49] - Answering Machine Over-ride Timer

This timer sets the amount of time that can be taken between calls when using the answering machine over-ride (see section [47] light 7). Valid entries are from 001 to 249 (in seconds) with a default of 060.

PROGRAMMING GUIDE

Introduction

The PC2550 is programmed by entering instructions from the panel keypad. The PC2550 memory is EEPROM and can be reprogrammed thousands of times. The EEPROM will not lose memory even on total AC and battery failure. All essential program information required to define the operation of the control panel and the communicator is stored in a section of the EEPROM which can only be accessed using the Installer's Programming Code. If the code is forgotten, the default program code can be re-inserted by using the "Hardware Reset" described on page 23, unless Installer's Lockout is enabled. See sections [90] and [91].

To begin programming the PC2550, enter [*] [8] [2550] while the panel is disarmed. Installer's Programming can only be done while the panel is disarmed and not in alarm. The factory default Installer's Programming Code is [2550]. This default code can be changed using the Section [24] command listed below (new Installer's Code). Once the basic Installer's command is entered ([*] [8] [2550]) the "Program" light will start to flash. The "Program" light will continue to flash while programming. Note that while programming, if no key entry is made for more than 2 minutes, the keypad will return to the arm-disarm mode and the complete installer's command ([*] [8] [2550]) must be entered before programming can resume.

The next step is to enter a 2 digit section entry for any of the commands described in the following pages. Note that while the keypad is waiting for the section entry the "Armed" light is on steady. As soon as the 2 digits are entered for the section the keypad will beep 3 times, the "Armed" light will go out and the "Ready" light will go on. The keypad is then ready to accept data entry for the selected section.

A complete description of each programming section will be given in the remaining pages of this section. A programming work sheet summarizing all programming commands is provided in the next section of the manual. Fill out the work sheet and use it as a guide when programming.

As the required data for a programming section is entered, the hexadecimal value of the information in that location is displayed on zone lights 1-4. Most sections contain several groups of two digit entries. The keypad beeps twice and the "Armed" light flashes after each group of two digits is entered. When the required data is completely entered for the section being programmed, the keypad will beep 5 times and the "Armed" light will come back on to indicate that the expected data has been entered and another section can be selected for programming. After completing one section, it is not necessary to re-enter the [*] [8] [Installers' code] portion of the command. Just enter the number of another programming section. When programming a section, it is possible to exit by pressing [#]. Only the data entered before pressing [#] will be changed in the EEPROM. Practice entering data in several sections until you become familiar with the programming commands.

Certain programming entries may require "HEX" data. That is the numbers 0 through 9 and the letters A through F (in "HEX" numbering the letters A...F represent the numbers 10...15).

Where commands require "HEX" data A-F, first press [*]. The keys 1-6 now assume the hex values A-F and the "Ready" light begins to flash. Key 1=A, Key 2=B, Key 3=C, Key 4=D, Key 5=E and Key 6=F. Pressing the [*] again stops the "Ready" light from flashing and the keys assume the normal values for

the numbers from 1 to 9. The most common mistake in entering "HEX" data is forgetting to press [*] again after entering the "HEX" digit to return to normal number entry.

The data for sections 15, 16, 17, 18, 19, 31, 32, 33, 34, 47, 48, 52 and 53 is entered using the keypad zone lights to indicate which functions are active and the number keys to turn functions on and off. When the section number is entered, the zone lights 1..8 will display which functions are currently on. Pressing the number key corresponding to the zone light alternately turns the function on and off. All functions can be turned off by entering [0]. When the correct selections have been made press [#] to record them in memory and to go on to program the next section.

Binary Data Display

Zone lights 1 through 4 are used to display the binary value of the data as shown in the table below.

Value	Hex Data Entry*															
	0	1	2	3	4	5	6	7	8	9	A	B	C	D	E	F
Zone 1	<input type="checkbox"/>	<input checked="" type="checkbox"/>	<input type="checkbox"/>	<input checked="" type="checkbox"/>	<input type="checkbox"/>	<input checked="" type="checkbox"/>	<input type="checkbox"/>	<input checked="" type="checkbox"/>	<input type="checkbox"/>	<input checked="" type="checkbox"/>	<input type="checkbox"/>	<input checked="" type="checkbox"/>	<input type="checkbox"/>	<input checked="" type="checkbox"/>	<input type="checkbox"/>	<input checked="" type="checkbox"/>
Zone 2	<input type="checkbox"/>	<input type="checkbox"/>	<input checked="" type="checkbox"/>	<input checked="" type="checkbox"/>	<input type="checkbox"/>	<input type="checkbox"/>	<input checked="" type="checkbox"/>	<input checked="" type="checkbox"/>	<input type="checkbox"/>	<input type="checkbox"/>	<input checked="" type="checkbox"/>	<input type="checkbox"/>	<input type="checkbox"/>	<input type="checkbox"/>	<input checked="" type="checkbox"/>	<input checked="" type="checkbox"/>
Zone 3	<input type="checkbox"/>	<input type="checkbox"/>	<input type="checkbox"/>	<input checked="" type="checkbox"/>	<input checked="" type="checkbox"/>	<input checked="" type="checkbox"/>	<input checked="" type="checkbox"/>	<input type="checkbox"/>	<input type="checkbox"/>	<input type="checkbox"/>	<input type="checkbox"/>	<input type="checkbox"/>	<input checked="" type="checkbox"/>	<input checked="" type="checkbox"/>	<input checked="" type="checkbox"/>	<input checked="" type="checkbox"/>
Zone 4	<input type="checkbox"/>	<input type="checkbox"/>	<input type="checkbox"/>	<input type="checkbox"/>	<input type="checkbox"/>	<input type="checkbox"/>	<input type="checkbox"/>	<input checked="" type="checkbox"/>	<input checked="" type="checkbox"/>	<input checked="" type="checkbox"/>	<input checked="" type="checkbox"/>	<input checked="" type="checkbox"/>	<input checked="" type="checkbox"/>	<input checked="" type="checkbox"/>	<input checked="" type="checkbox"/>	<input checked="" type="checkbox"/>

Light On
 Light Off

*See Hex Data Entry instructions below

Reviewing Programmed Data

Enter the section you wish to review by entering the 2 digit section number. The zone LEDs will represent the value (hexadecimal format) of the first digit in that section. Each press of the 'F' key will advance the display to the next digit. At the end of the section, the keypad buzzer will beep several times and return you to the program mode where another section can be selected for review or programming.

Note: Only sections [01] through [14], [20] through [30], [35], [46], [49], [50], [54] and [55] can be reviewed using the above method.

[00] Binary Programming

This section is normally used upon instruction from factory technical personnel for specialized programming not covered by the standard programming instructions.

[01] 1st Phone Number

This is the 1st telephone to which the communicator will dial. See section [35] "Transmission to 1st or 2nd Telephone Number Options". After entering the section number [01], enter the communicator telephone number the way you would dial it on a telephone. Press [#] after the last digit to complete the telephone number programming.

Enter [* 2 *] to dial a '*' (Hex B)

Enter [* 3 *] for a 4 second pause (Hex C)

Enter [* 4 *] for additional dial tone search (Hex D)

Enter [* 5 *] to dial a '#' (Hex E)

The total number of digits including dial tone searches and pauses must not exceed 17. Remember to press [#] after entering the last digit of the phone number. Press [02] to program the next section, enter another section number or press [#] a second time to return to the arm/disarm mode.

[02] 1st Account Code

The 1st account code is always transmitted to the 1st phone number to identify the alarm customer. After entering the Section number [02], enter a 4 digit number. If "HEX" digits A to F are required; enter [*], [1]...[6] and [*] again to return keys to normal decimal entry. Where a zero digit in the account code is required use "HEX A" ([*][1][*]) to transmit 10 pulses. The receiver at the monitoring station interprets 10 pulses for a digit as a zero. If a three digit code is required as in 3/1 formats, enter [0] as the last digit. [0] represents a null digit....no pulses transmitted.

[03] 2nd Phone Number

This is the second telephone number to which the communicator will dial. See section [01] "1st Phone Number" for programming instructions.

[04] 2nd Account Code

The 2nd account code is always transmitted to the 2nd phone number. See section [02] "1st Account code" for programming instructions.

Reporting Codes Explanation

Sections [05] to [13] are used to program the communicator reporting codes. A reporting code is transmitted along with the account code with each transmission. If the reporting codes are not programmed in these sections no transmission will be sent when an event (i.e. alarm, restoral, opening/closing, trouble etc.) takes place. To prevent a transmission from being sent for any event in the following sections leave it unprogrammed or enter [00] as the reporting code.

Between 6 to 10 reporting codes are programmed in each section. Once the section number is entered, the keypad expects 6 to 10 two digit numbers to be entered for the number of reporting codes in that section. The keypad beeps twice and the "Armed" light flashes after each 2 digit number is entered. After the last code is entered, programming of the current section is complete. The keypad will beep 5 times, the "Ready" light will go off and the "Armed" light will go on. The keypad is then ready to accept the next section number for programming.

When changing the reporting codes in a section, only code entries up to the one which is being changed need to be entered. Press [#] to exit from the programming sequence. Only codes up to the last one entered will be changed.

[05] Alarm Reporting Codes Zones 1 to 8

Once the Section code [05] is entered, the keypad expects 8 two digit numbers to be entered as the reporting codes for zones 1 to 8 alarms (restorals in section [06]). These codes are used by the communicator when there has been an

alarm on zones 1 to 8. Listed below are several programming examples and the resulting transmission using different formats for the reporting codes. Obtaining different formats requires entering data correctly in the account code section ([02] or [04]) reporting codes sections ([05] to [13], [50], [54] and [55]) and communication format options, section ([29]).

3/1 Format....Single Line or Non-extended Reporting

Required:

- 3 digit account code in sections [02] or [04]
i.e. enter [1230] for account code 123
- Format code [0], [1], [2], [3], [4] depending on receiver type selected in section [29]
- Single digit alarm reporting code in section [05]
i.e. enter [30] for single digit code 3 (0 is null digit i.e. no pulses transmitted)

Transmission sent:

- 123 3

4/2 Format....Single Line Reporting

Required:

- 4 digit account code in Sections [02] or [04]
i.e. enter [1234] for account code 1234
- Format code [0], [1], [2], [3], [4] depending on receiver type selected in section [29]
- Two digit alarm reporting code in section [05]
i.e. enter [31] for two digit code 31

Transmission sent:

- 1234 31

3/1 Format....Extended Reporting

Required:

- 3 digit account code in Sections [02] or [04]
i.e. enter [1230] for account code 123
- Format code [8], [9], [A], [B], [C] depending on receiver type selected in section [29]
- Two digit alarm reporting code in section [05]
i.e. enter [31]

Transmission sent:

- 1st round 123 3
- 2nd round 333 1

If a transmission is not wanted for a particular reporting code, then enter 00 to disable that reporting code.

[06] Restoral Reporting Codes Zones 1 to 8

These reporting codes are used by the communicator to transmit a zone alarm for zones 1 to 8. Use instructions in section [05] as a guide for programming.

[07] Reporting Codes for Closing (Arming) with Access Codes 1 to 8

The reporting codes in sections [07] to [10] are used to identify "Openings and Closings" (disarming and arming of the system) by user access code.

After entering the section code [07], enter 9 two digit reporting codes. The 9 reporting codes correspond to the first 8 access codes which are programmed using the [*][5] command and then the partial closing code in last. When the system is armed using one of the access codes, the corresponding reporting code is transmitted.

When transmitting in any of the extended formats, (see examples in section [05]), closing codes would be programmed as follows. [C1], [C2], [C3], [C4], [C5], [C6], [C7], [C8].....Where the first digit "HEX C" is one which is used to represent a closing signal (this could be another number depending on what is used at the monitoring station) the 2nd digit represents the access code which was used to arm the system.

The closing code transmission takes place after the exit delay time. Therefore if the system is armed and disarmed before the expiry of the exit time, no transmission will take place.

Remember that the 1st access code is the Master Code and that the 16th code may be the temporary or maid's code. The 16th access code can be converted to a normal code by turning light 8 off in section [15].

When the system has been armed using "Quick Arm" [*][0] or "Auto-arm" (see [*][6] "Keypad Commands"), the 1st reporting code (reporting code for Master Code) will be transmitted. The Master Code is required to enable or disable these functions.

When the system is armed with one or more zones bypassed (see [*][1] command for zone bypassing), the monitoring station can be notified by programming the Partial Arm reporting in section [16]. Note that the partial closing code is sent in tandem with the regular closing code to identify it as a partial closing condition. If section [16] light 1 is on then the bypassed zones will be identified between the partial closing and the closing code by sending their alarm code transmissions.

[08] Reporting Codes for Closing (Arming) with Access Codes 9 to 16

The Auto-arm Cancel code is described on page 10 under Auto-arm Time of Day. See section [07] for programming information.

[09] Reporting Codes for Opening (Disarming) with Access Codes 1 to 8

The 8 reporting codes correspond to the first 8 access codes which are programmed using the [*][5] command. When the system is disarmed using one of the access codes, the corresponding reporting code in this section is transmitted.

See section [07] for an example of "Opening and Closing" reporting code programming.

[10] Reporting Codes for Opening (Disarming) with Access Codes 9 to 16

See section [09] for further information.

If the opening after alarm code is programmed, that code will be transmitted to the monitoring station on opening if an alarm occurred during the previous armed period. This feature is useful for installations where openings and closings are not reported normally but it is desired to have a report to the monitoring station on opening if an alarm did occur during the previous armed period. This feature allows the monitoring station to know when the user is on the premises and available to receive a report about alarms that occurred while the system was closed.

[11] Reporting Codes for Priority Alarms and Restorals

These reporting codes are used by the communicator to transmit the following list of alarm and restoral conditions. Use instructions in section [05] as a guide for programming. See "Terminal Connections" section of manual for a description of the operation of the Fire Zone and the Auxiliary Input Zone. Section [30] contains options for Auxiliary Input Zone.

- Fire Zone
- Auxiliary Input Zone
- Keypad Panic Alarm [P]
- Keypad Fire Alarm [F]
- Keypad Auxiliary Alarm [A]
- Fire Zone Restoral
- Auxiliary Input Zone Restoral
- Keypad Panic Restoral [P]
- Keypad Fire Restoral [F]
- Keypad Auxiliary Restoral [A]

[12] Reporting Codes for Maintenance Alarms

The reporting codes programmed in this section include the periodic test reporting code (every 1 to 99 days) and trouble conditions. The battery trouble reporting code will be sent when the battery voltage drops below 11.3 volts. This reporting code will also be sent because of a battery fuse failure. The battery is tested under load every 4 minutes. The AC failure trouble reporting code will be sent after the delay time programmed in section [20]. This prevents transmissions during temporary power failures. Auxiliary power supply trouble reporting code is sent when the auxiliary power supply fuse is blown. The bell circuit trouble reporting code is sent when the bell circuit is open or the fuse is blown. The fire zone trouble code is sent when the fire zone becomes open circuit (E.O.L. resistor is disconnected). The day zone trouble code is sent when any zone defined as a day zone (see section [14]) goes open when the system is disarmed. See [*][2] Trouble Command for additional description of trouble codes and transmissions. The periodic test cycle time is set in section [20] and reporting time of day is set in section [23].

The reporting codes are programmed in the following order.

- Battery Trouble
- AC Trouble
- Day Zone(s) Trouble
- Bell Circuit Trouble
- Fire Zone Trouble
- Auxiliary Power Supply Trouble
- Periodic Test Transmission

[13] Reporting Codes for Maintenance Restorals

See section [12] for further information.

- Battery Trouble Restoral
- AC Trouble Restoral
- Day Zone(s) Trouble Restoral
- Bell Circuit Trouble Restoral
- Fire Zone Trouble Restoral
- Auxiliary Power Supply Trouble Restoral

[14] Zone Definitions for Zones 1 to 8

As in section [5], once this section number is entered, 8 two digit numbers are required. Each 2 digit number entered describes how a zone will operate. The 8 two digit numbers entered correspond to zone definitions for zones 1 to 8.

1st Digit	2nd Digit
0 = Slow, audible	0 = Standard delay
1 = Slow, silent	1 = Instant
2 = Fast, audible	2 = Interior
3 = Fast, silent	3 = Home-Away
	4 = 24 Hour..bell
	5 = 24 Hour..bell/buzzer
	6 = 24 Hour buzzer
	7 = Auxiliary delay
	8 = Day

The 1st Digit determines whether the zone will cause a silent alarm or an audible alarm and whether the zone response will be fast or slow. Slow zone response time can be programmed in section [20] and can be set from 10 to 990 ms. The factory default zone response time is 500 ms. If set at fast, the zone response time is 20 ms and, if set at slow, the zone response time is 500 ms or whatever time is set in section [20].

The 2nd Digit determines the zone type, [0] through [8] as described below.

[0] = Standard Delay Zone has an entry and exit delay and is normally used for entry/exit doors. The exit delay starts as soon as the panel is armed. The zone may be opened and closed during the delay time without causing an alarm. After the exit delay time has expired, opening the zone will start the entry delay timer. During the entry delay time, the keypad

buzzer will sound steadily to advise the user that the system should be disarmed. If the panel is disarmed before the entry time expires, no alarm will be generated.

The default times for this type of zone are a 30 second entry delay and a 120 second exit delay. The entry and exit delays may be independently programmed in section [20] for periods from 1 to 255 seconds. All zones programmed as type [0] will have the entry and exit delays as programmed in section [20] or the default times if section [20] is not programmed.

[1] = Instant Zone is normally used for door and window contacts and has the standard exit delay but is instant when opened after the exit delay expires. The exit delay will be the default time of 120 seconds or the time as established in programming section [20].

[2] = Interior Zone is normally used with interior motion detectors and has the standard exit delay time. The zone also has the standard entry delay time provided that a delay zone has been tripped first. If the premises are entered without coming through a "delay" entrance, and a type [2] zone is tripped, an immediate alarm will be generated.

[3] = Home-Away Zone operates the same as the type [2] zone with the following exception. If the system is armed and the delay zone is NOT tripped during the exit delay time, the type [3] zone will be bypassed. Instead of the interior portion of an interior Home-Away zone, a Home-Away zone can have a delay equal to the standard entry delay when section [17], light 5 is on. This will affect all Home-Away zones when they are not bypassed by [*][1], [*][9] arming, or by arming and not leaving the premises. If Home-Away zones are automatically bypassed or [*][9] arming bypassed and the user then goes [*][1], the Home-Aways will then have a delay if the feature is enabled and will be a type [2] zone if not.

[4] = 24 Hour Bell Zone is active at all times and will create an alarm if the panel is armed or disarmed. This zone will always activate the bell/siren output.

[5] = 24 Hour Bell/Buzzer operates as the type [4] except the bell/siren output is activated only when the panel is armed and only the keypad buzzer is activated while the panel is disarmed.

[6] = 24 Hour Buzzer operates as the type [4] except only the buzzer will be activated in the armed or disarmed mode.

[7] = Auxiliary Delay Zone operates the same as the type [0] zone except the entry/exit times can be independently set in section [21]. This zone type is useful when a zone with an entry and/or exit time is required that is different from the standard times as established for type [0] zones in section [20]. If section [17], light 6 is on it will enable the system to be armed even if the aux delay zone is open ("Ready" light ON). Also, the system can be armed with the aux delay zone closed and then it can be opened before the aux exit delay has expired. In both cases the aux delay zone will not become active until both the aux exit delay has expired and the zone is closed. If force arming of type [7] zones is used, quick exit must not be used.

[8] = Day Zone is a variation of a 24 hour circuit. It operates as a type [5] zone by ringing the bell or siren at night and the keypad buzzer during the day (2 beeps every 10 seconds; pressing any key silences keypad buzzer). However, a trouble transmission (programmed in section [12]) is sent when the system is disarmed rather than an alarm transmission (programmed in section [05]).

[15] 1st System Option Code

The 1st system option code is set using the zone lights to indicate which options in the following list are active. Once section [15] is entered the 8 zone lights will indicate which options are active. Press the corresponding number key to turn an option on or off. Press [0] to turn all options off.

[1] Communicator Disable/Enabled

On = Communicator disabled.

The system's communicator will be shut off and events will not be transmitted to the monitoring station.

* Off = Communicator enabled.

The system's communicator will be enabled and all events with reporting codes will be reported to the monitoring station. Refer to the Telephone Number, Reporting Code and Call Direction Programming Sections.

[2] Restorals Reporting Option

On = Restorals on Bell Time-Out.

Zone restoral reporting codes will not be transmitted until the zone has been restored and the Bell Cut-off Time has expired. If the zone is still active when the Bell Cut-off Time expires, the restoral will be transmitted when the zone restores or when the system is disarmed. Note that 24-hour zones will not restore until the zone is mechanically restored.

* Off = Restorals Follow Zones.

Zone restoral reporting codes will be transmitted when the zone is mechanically restored. If zones are still active when the system is disarmed, the restoral codes will be transmitted when the system is disarmed. Note that 24-hour zones will not restore until the zone is mechanically restored.

[3] Alarm Display Options

On = Alarms Display While Armed.

Alarm conditions will be displayed on system keypads whether the system is in the armed or disarmed state.

* Off = Alarms Displayed While Disarmed Only.

Alarm conditions will be displayed only when the system is in the disarmed state.

[4] DTMF or Pulse Dialing

On = DTMF Dialing.

The control panel will dial telephone numbers using DTMF (dual tone multi-frequency) dialing for the first 2 attempts. For attempts 3 through 8, the panel will use pulse (rotary) dialing.

* Off = Pulse Dialing.

The control panel will dial telephone numbers using pulse (rotary) dialing for all 8 attempts.

[5] Zone Loop Options

On = Normally Closed Zones.

All zones are wired as normally closed circuits with return to ground. An alarm will be generated when the circuit is opened.

* Off = End-of-Line Resistor Zones.

All zones must be wired with an end-of-line resistor connected between the "ZONE" and "COM" terminals. An alarm will be generated when the circuit is opened or shorted. If the zone is programmed as a Fire Zone, an open circuit will be reported as a Fire Trouble, and a short circuit will be reported as a Fire Alarm.

[6] [P] Key Bell Options

On = [P] Key Audible Alarm.

The BELL output will be activated when the [P] key is pressed and held for 2 seconds.

* Off = [P] Key Silent Alarm.

The BELL output will not be activated when a [P] key alarm is generated.

[7] Transmission Back-up Options

* On = Call 1st Telephone Number Only.

When events programmed to report to the 1st Telephone Number are to be transmitted, up to 8 attempts will be made to communicate to the 1st Telephone Number. If all 8 attempts to communicate fail, a Failure to Communicate Trouble will be generated.

Off = Back-up to 2nd Telephone Number.

If 8 attempts to communicate to the 1st Telephone Number fail, up to 8 attempts will be made to communicate to the 2nd Telephone Number. If all 8 attempts to communicate to the 2nd Telephone Number fail, a Failure to Communicate Trouble will be generated.

Note: Do not program backup to 2nd Telephone Number if no 2nd Telephone Number is programmed.

[8] Maid's Code (One Time Use Code) Option

On = Maid's Code (One Time Use Code) Enabled.

Access Code 16 may be used to disarm and then later arm the system only once. After the Maid's Code (One Time Use Code) is used to arm the system, it will be deleted and will not be able to arm or disarm the system.

* Off = Maid's Code (One Time Use Code) Disabled.

Access Code 16 functions as a normal access code.

* is default condition.

[16] 2nd System Option Code

Use same method of programming as used in section [15].

[1] Partial Closing Identification Options

On = Partial Closings Identified.

The alarm codes for all bypassed zones will be transmitted after the Partial Closing Code and before the Closing Access Code when the system is armed.

* Off = Partial Closings Not Identified.

Bypassed zones will not be identified when the system is armed; only the Partial Closing Code and the Closing Access Code will be transmitted.

[2] Master Code Options

On = Master Code Not User-Changeable.

The Master Code may not be changed by the user, and may only be programmed in the Installer's Programming Mode.

* Off = Master Code User-Changeable.

The Master Code may be programmed by the user using the [*][5][Master Code] command. The Master Code may also be programmed in the Installer's Programming Mode.

[3] Bell Squawk Options

On = Bell Squawk on Arming and Disarming.

The bell or siren will sound a single squawk when the system is being armed, and a double squawk when the system is being disarmed.

* Off = No Bell Squawk.

The bell or siren will not squawk when the system is armed or disarmed.

[4] PC16OUT Options

On = PC16OUT Module Enabled.

A PC16OUT module may be connected to the control panel; refer to the PC16OUT Installation Sheet.

* Off = PC16OUT Module Disabled.

The system will not support the use of a PC16OUT Module.

[5] Telephone Line Monitor Trouble Options

On = TLM Trouble Only.

A Telephone Line Monitor Trouble will generate a trouble indication; the "Trouble" light will come ON and the keypad sounder will beep until the [*][2] View Trouble Conditions Command is entered.

Note: The "Trouble" light will not come ON in the armed state.

* Off = TLM Audible When Armed.

When the system is disarmed, a Telephone Line Monitor Trouble will generate a trouble indication as described above. If the system is armed, a Telephone Line Monitor trouble will generate an audible alarm on the bell or siren.

[6] Radionics Handshake Frequency Selection

On = 1400Hz Handshake.

The system will accept handshake tones at 1400Hz when using Radionics communications formats.

* Off = 2300Hz Handshake.

The system will accept handshake tones at 2300Hz when using Radionics communications formats.

Consult with the monitoring station to determine which communication formats and handshake frequencies are required.

[7] Telephone Line Monitor Disabled/Enabled

On = Telephone Line Monitor Disabled.

The TLM function will be shut off and telephone line troubles will not be indicated by the system.

* Off = Telephone Line Monitor Enabled.

The TLM function will be active and the system will indicate Trouble Condition 4 when using the [*][2] View Trouble Conditions Command.

[8] Bypass and Access Code Options

On = Access Code Required to Bypass Zones.

After entering the [*][1] Bypass Zones Command, an access code must be entered before zones may be bypassed.

* Off = Access Code Not Required to Bypass Zones.

Enter the [*][1] Bypass Zones Command to bypass zones.

* is default condition.

[17] 3rd System Option Code

[1] Bell During Auto-arm Options

On = Bell During Auto-arm Disabled.

The bell or siren will not be activated during the 1 minute Auto-arm warning time.

* Off = Bell During Auto-arm Enabled. The bell or siren will sound a single squawk every 10 seconds during the 1 minute Auto-arm warning time.

[2] AC Trouble Options

On = AC Excluded from Trouble.

If AC power fails, the condition will be reported to the monitoring station but will not be indicated on the system keypads.

* Off = AC Trouble Reported and Displayed.

If AC power fails, the condition will be reported to the monitoring station and will be indicated as a Trouble condition on the system keypads.

[3] Zone Power-up Options

On = 120 Second Bypass of Zones on Power-Up.

When power is first applied to the system, all zones will be bypassed for two minutes. This is to allow time for the detection devices to "settle" without causing false alarms. After 2 minutes, the zones will be active.

* Off = Zones Active on Power-up.

All zones will be active when power is applied to the system.

[4] Auto-arm Cancellation Options

On = Auto-arm Cancel Requires Access Code.

An access code must be entered to cancel the Auto-arm sequence during the 1 minute Auto-arm warning time.

* Off = No Code Required.

Pressing any key during the 1 minute Auto-arm warning time will cancel the Auto-arming sequence.

[5] Home-Away with Delay Options

On = Home-Away with Delay.

All zones programmed as Home-Away will have an Entry Delay if a Delay Zone is activated while the system is armed. The Home-Away zones will have an Exit Delay if they are activated using the [*][1] command.

* Off = Home-Away as Interior.

All zones programmed as Home-Away types will not be subject to the Entry or Exit Delays. When the Home-Away zones are armed, any activity on the zones will generate an immediate alarm. These zones will not have an Exit Delay if they are activated using the [*][1] command.

[6] Auxiliary Delay Zones Force Arming Option

On = Force Arm on Auxiliary Delay.

The system may be armed with Auxiliary Delay Zones being left open. When the system is armed, the Auxiliary Delay Zones will be bypassed. When the zones are secured, they will be added to the system and will be armed. Once armed, activity on an Auxiliary Delay Zone will initiate the Auxiliary Entry Delay.

* Off = Auxiliary Delay Normal.

If an Auxiliary Delay Zone is left open when the system is armed, the Auxiliary Entry Delay will begin as soon as the Exit Delay expires. If the system is not disarmed before the Auxiliary Entry Delay expires, an alarm will be generated.

[7] Transmission Limit Reset Options

On = Transmissions Limited to 24-hour Period.

The Swinger Shutdown counter will be reset when the system time changes from 23:59 (11:59 pm) to 00:00 (12:00 am).

* Off = Transmissions Limited to Armed Period.

The Swinger Shutdown counter will be reset when the system is next armed.

The Swinger Shutdown counter is used to limit the number of alarms each zone may transmit. When a zone has generated the set number of alarms, any further alarms will be ignored and will not be transmitted. When the Swinger Shutdown counter is reset, zones that had been "shut down" after transmitting the set number of alarms will again be able to transmit alarms.

[8] Bypass Status Display Options

On = Show Bypass Status While Armed.

The "Bypass" light will be ON while the system is armed to indicate that there are bypassed zones on the system.

* Off = Show Bypass Status While Disarmed Only.

The "Bypass" light will be ON only while the system is disarmed to indicate that there are bypassed zones on the system. When the system is armed, the "Bypass" light will be shut OFF.

* is default condition.

[18] 4th System Option Code

[1] Quick Exit Enable/Disable

On = Quick Exit Enabled.

With the system armed in the Home-Away mode, users may enter the [*][0] command to allow a single delay zone to be activated so they may leave the premises. Only one delay zone may be activated; any additional activity on another delay zone will generate an alarm. If the delay zone is still open 2 minutes after the [*][0] command is entered, the Entry Delay will be initiated.

* Off = Quick Exit Disabled.

Note: Quick exit shall not be enabled on UL listed systems.

[2] Bell Pulse Options

On = Bell Pulses Always.

The bell or siren will pulse for all types of audible alarms.

* Off = Bell Pulses for Fire Alarm Only.

The bell or siren will pulse for Fire and [F] key alarms. For all other audible alarms, the bell or siren will sound a steady alarm.

[3] Bypassed Zone Display Options

On = Show Bypassed Zones Always.

The zone lights of bypassed zones will come ON upon expiry of the Exit Delay as well as when the [*][1] command is executed in the disarmed state.

* Off = Show Bypassed Zones While Disarmed Only.

The zone lights will only come ON when the [*][1] command is executed in the disarmed state.

Note: If Alarms Displayed While Armed is enabled, bypassed zones will not be displayed while the system is armed.

[4] 2-minute Keypad Time-out Enabled/Disabled

On = 2-minute Keypad Time-out Enabled.

If no keys are pressed for 2 minutes, all keypad lights will be shut OFF.

* Off = No Keypad Time-out.

The keypad lights will not be shut OFF.

Note: This feature must not be used with an LCD keypad or an Escort.

[5] Partial Closing Reporting Option

On = Partial Close on Auto-arm.

When the system is armed with open zones, the system will transmit the Partial Closing Code, the Alarm Reporting Codes for the Force-Armed zones, and the User Closing Code.

* Off = No Partial Close on Auto-arm.

The system will transmit only the User 1 Closing Code even though zones were force armed.

[6] [P] Key Keypad Sounder Options

On = Keypad [P]anic Silent Buzzer.

When a [P] key alarm is generated, the keypad sounder will not beep to acknowledge the alarm.

* Off = Keypad [P]anic Audible Buzzer.
When a [P] key alarm is generated, the keypad sounder will beep 3 times to acknowledge the alarm.

[7] [F] Key Enabled/Disabled

On = [F] key Disabled.
The [F] key will not sound an alarm or communicate when pressed.

* Off = [F] key Enabled.
Pressing and holding the [F] key for 2 seconds will generate a Fire alarm; the bell or siren will sound with a pulsing tone, and an alarm reporting code (if programmed) will be transmitted.

[8] Bell Shutdown Enabled/Disabled

On = Bell Shutdown Enabled.
The BELL output will not be activated for zones that have exceeded the limit of alarms set in the Swinger Shutdown counter.

* Off = Bell Shutdown Disabled.
The BELL output will be activated for all alarms on all zones, even after the Swinger Shutdown counter has been exceeded. The BELL output will continue to be activated for all alarms, even though the alarms will not be reported once the Swinger Shutdown counter has been exceeded.

* is default condition

[19] Zones 1 to 8 Bypass Mask

Use the same method of programming as used in section [15]. Using this section it is possible to control which zones the user is able to bypass using the [*][1] command. If the zone light is on the zone can be bypassed. If the zone light is off that zone cannot be bypassed.

[20] System Times

Once the section number is entered, 6 three digit numbers are expected to be entered. The valid range for entries in this section is 001 to 255. Hex values or 00 are not allowed. The times are entered in the following order:

- Entry delay time (in seconds)
- Exit delay time (in seconds)
- Bell cut off time (in minutes)
- Delay before AC failure trouble reporting (in minutes)
- Slow zone response time (in 10 ms increments)
- Default zone response - 500 ms
- Test transmission/periodic download cycle time (in days)

AC Failure Reporting Code is transmitted after a delay, which may be 255 minutes, programmed. The reporting code for AC Failure Trouble and Restoral is programmed in sections [12] and [13].

Zone Response Time is the length of time that an alarm condition must be present on a zone before it is detected. Certain vibration detectors, shock sensors and glass break

detectors require a fast response zone in order to operate. The zones to which these types of detectors are connected should be programmed as fast response zones. All other zones should be programmed as slow response zones. Zones are defined as either fast or slow response time in section [14]. The fast response time is fixed at 20 ms. The Slow Zone Response Time is programmable in increments of 10 ms. The normal entry would be 50 for a 500 ms slow response time.

Test Transmission or Periodic Download is sent to the monitoring station on a regular basis to confirm that the communication link to the system is intact. The test transmission/periodic download cycle time is how often (in days) the test transmission and /or periodic download is sent. The reporting code for the test transmission is programmed in section [12]. The time of day that the test transmission and/or periodic download is sent is programmed in section [23].

To enable either option, lights 7 and 8 in section [48] must be programmed. If both test transmission and periodic download are enabled, the same time will be used for both. The test transmission will transmit first and after it goes off line a periodic download will take place.

[21] Auxiliary Delay Zone Times

This section requires 2 three digit entries to establish the auxiliary entry and exit delay times. Do not press the [#] key during data entry. The entry default time is 45 seconds and may be changed to any time from '001' second to '255' seconds. The exit default time is 180 seconds and may be changed to any time from '001' second to '255' seconds.

For the auxiliary delay times to be effective on a zone, the zone must be set as type [7] in section [14] Zone Definitions.

[22] Communication Variables

Once this section is entered, 2 two digit numbers are expected. Do not press the [#] key while entering data. The first two digit number defines the number of alarm and restoral pairs per zone that the communicator will make before it shuts down for that zone. (Swinger shutdown). The system will still go into a local alarm (Bell or siren) unless section [18] light 8 is on to make the bell follow the swinger shutdown counter. The counter may be reset either when the panel is armed or on a 24 hour basis as defined in the 3rd system option code, zone light 7. The number of alarms may be programmed from '00' to '99' where '00' means the communicator will never shutdown. The fire zone cannot be shutdown, it always transmits.

The second two digit number defines the delay before transmission. This delay is for zones defined as burglary zones only. 24 hour zones or the fire zone will not be delayed. The time may be programmed from '00' to '99' seconds where '00' means no delay. If the system is disarmed before the transmission delay expires, then no transmission will take place.

[23] System Clock Times

After the section number [23] is entered, three 4 digit numbers are expected. These numbers are the following system times:

- Automatic arming time of day (HH:MM)
- For future use (99:99)
- Test transmission time of day (HH:MM)

Times are entered using the "24 hour clock" (military time). Valid entries are 00 to 23 for HH (i.e. hours) and 00 to 59 for MM (i.e. minutes). **Note: IF INVALID TIMES ARE ENTERED FUNCTIONS WILL NOT WORK. The automatic arm function is enabled and disabled using the [*]+[6]+[Master Code] User's Function Commands.**

Note: For the following sections [24] to [28], enter a new 4 digit code. Once the section number has been entered, only use digits 0 to 9 as code numbers. Do not press the [*] or [#] keys.

If an error is made in entering a code, continue to enter the four digits then enter the section number again and re-enter the correct code. Do not press the [*] or [#] while entering these codes.

[24] Installer's Code

[25] Master Code (Access Code Number 1)

[26] 2nd Master Code

[27] Downloading Access Code

This 4 digit code allows the panel to confirm that it is communicating with a valid downloading computer. The factory default code is [2525].

[28] Panel Identification Code

This 4 digit code allows the downloading computer to confirm the identity of the control panel. The factory default code is [2501]. Do not make any of these codes the same.

[29] Communicator Format Options

This section sets the type of format which will be sent to each of the two telephone numbers programmed in sections [01] and [03]. Enter one HEX digit (i.e. when entering HEX "A" press [*][1][*]) for each. The number entered for each phone number is determined by the requirements of the receiver being called. Enter the format number for the "1st Telephone Number" first. It is necessary to program the

format number for each telephone number even if the first phone number is the only one being used. Options are as follows.

- [0] Silent Knight/Ademco slow, 10 BPS (1400 Hz handshake) 3/1 and 4/1, 4/2 non extended format
- [1] Sescoa, Franklin, DCI, Vertex, 20 BPS (2300 Hz handshake) 3/1 and 4/1, 4/2 non extended format
- [2] Silent Knight fast, 20 BPS (1400 Hz handshake) 3/1 and 4/1, 4/2 non extended format
- [3] Radionics, (2300/1400 Hz handshake)* 3/1, 4/2 non extended format
- [4] Radionics, (2300/1400 Hz handshake)* 3/1, 4/2 non extended with parity format
- [5] Sescoa super speed
- [6] Not used
- [7] Not used
- [8] Silent Knight/Ademco slow, 10 BPS (1400 Hz handshake) 3/1 extended format
- [9] Sescoa, Franklin, DCI, Vertex, 20 BPS (2300 Hz handshake) 3/1 extended format
- [A] Silent Knight/Ademco fast, 20 BPS (1400 Hz handshake) 3/1 extended format
- [B] Radionics, (2300/1400 Hz handshake)* 3/1 extended format
- [C] Radionics, (2300/1400 Hz handshake)* 3/1 extended with parity format
- [D] Sescoa super speed (with identified openings/closings)
- [E] Not used
- [F] Not used

* See section [16] light 6 for Radionics Handshake Option.

10 BPS and 20 BPS Formats

10 BPS is the standard slow format used on Silent Knight/Ademco receivers.

DATA=1900 Hz KISSOFF=1400 Hz SPEED=10 BAUD

20 BPS is the standard fast format used on DCI, Franklin, Sescoa and Vertex receivers.

DATA=1800 Hz KISSOFF=2300 Hz SPEED=20 BAUD

Radionics Format

For conventional 3/1 Radionics format the communications mode should be set to either Radionics rounds [B] or Radionics parity [C]. The extended version of the Radionics format is normally used. The following guidelines have been provided to help in configuring the PC2550 for Radionics format.

- The customer account code must be only 3 digits with a zero making up the 4th digit (i.e. program 1230 for account code 123).
- The zone alarm reporting codes must all be single digit numerical codes with no extended 2nd round being sent. The zero in the 2nd digit of the reporting code tells the PC2550 not to send an extended round.
- All other non-alarm reporting codes must be set up to send an extended 2nd round. The 1st digit of the reporting code is used to identify the event while the 2nd or extended digit is used to associate the event with a particular item. (i.e. A reporting code of E3 means restore zone 3. E for restore and 3 for zone 3.)
- The following is a list of 1st digit identifiers that should be used with the Radionics format.

Restorals "E"	Example "E3" = Restore Zone 3
Openings "B"	Example "B2" = Opening by User 2
Closings "C"	Example "C4" = Closing by User 4
Troubles "F"	Example "F5" = Trouble from Source 5
Misc "D"	Example "D1" = Partial Closing

Sescoa Super Speed Format

The SESCOA Super Speed Format must be programmed exactly as follows to function correctly.

- The account code must be four decimal digits in length and in the range of 0001 to 3374.
- The reporting codes must be 2 digits in length and programmed as follows.

Alarms Zones 1-8 (section [05])	A1 to A8
Restorals Zones 1-8 (section [06])	A1 to A8
All Opening Codes (sections [09] and [10])	BA
All Closing Codes (sections [07] and [08])	CA
Partial Closing (section [07])	C1
Low Battery (section [12])	E1
Battery Restorals (section [13])	E1
AC Failure (section [12])	E1
AC Restoral (section [13])	E1
Bell CCT. Trouble (section [12])	F1
Bell CCT. Restoral (section [13])	F1
Troubles (sections [12] and [13])	AA
Misc Alarms (section [11])	(A1 to 99)
Test Code (section [12])	1C or DC
System Test Code (section [50])	CC
After Alarm Code (section [10])	B1
Auto-arm Cancel Code (section [08])	C8
TLM Restoral Code (section [50])	EE

[30] Programmable Input and Output Options

Both the Auxiliary Input Zone and the Programmable Output have options which are programmed in this section. After the section number [30] is entered, enter 2 HEX digits from the following lists.

1st digit Auxiliary Input Zone

- [1] Silent 24 hour input
- [2] Audible 24 hour input
- [3] Momentary arming input
- [4] Forced Answer

When option [4] is selected, a high input (+12 V) will force the panel to pick up the phone line and await communications from downloading. This option is used for on-site downloading or for use with the LINKS Cellular Alarm Transmitter.

See Auxiliary Input Terminal in the "Terminal Connections" section on page 4 for details on the Auxiliary Input. When option [3] is selected, a momentary key closure between the Auxiliary Input and the Positive Auxiliary Power Supply will alternately arm and disarm the system. The reporting codes for the Auxiliary Input (section [11]) can be used as opening and closing codes for key arming but will only be transmitted with side A openings and closings.

2nd Digit Programmable Output

See Programmable Output Terminal in the "Terminal Connections" section on page 4 for details on connecting the "PGM OUT" terminal.

- [0] **LINKS Support Output** Select this option if a LINKS 1000 Cellular Alarm Transmitter is to be used with the panel. The PGM output terminal is used to control the LINKS 1000. The PGM output will activate the LINKS 1000 after an unsuccessful communication attempt on the regular phone line.

- [1] **Ground Start Pulse** provides a 2 second ground start pulse before dialing begins to obtain the dial tone on ground start telephone equipment.

- [2] **Utility Output ([*][7]) No Access Code**

- [3] **Utility Output ([*][7]) Any Access Code**

- [4] **Utility Output ([*][7]) Group A Access Code**

- [5] **Utility Output ([*][7]) Group B Access Code**

These options change the "PGM OUT" terminal to different options used with the keypad utility output [*][7] command. See Utility Output Command in the "Keypad Command" section.

- [6] **Keypad Buzzer Follow Mode** With this option the "PGM OUT" terminal switches to ground as long as the keypad buzzer is on.

- [7] **System Status (Arm/Disarm) Output** With this option the "PGM OUT" terminal switches to ground when the panel is armed. The switch is open when the panel is disarmed.

[8] Strobe Output (Latched Alarm Output) With this option the "PGM OUT" terminal switches to ground after an alarm and remains switched on until the system is disarmed.

[9] Failure to Communicate Output With this option the "PGM OUT" terminal switches to ground if the system fails to communicate with the monitoring station after 8 attempts. The output stays switched to ground until a successful communication takes place or until trouble #5 is cleared from the keypad. This option may be used to tie two systems together. One system can then be made to report a communication failure for the other.

[A] TLM and Alarm With this option the "PGM OUT" terminal switches to ground if the system has a TLM fault and any alarm condition. The output follows the length of 'bell time out'.

[B] Courtesy Pulse With this option the "PGM OUT" terminal switches to ground during the course of the entry and exit times. It could be used to turn on a light near the exit for the duration of the entry/exit times.

[C] PGM Squawk Output must be selected in order to use PGM Squawk on Entry/Exit Delay options in section [59].

[D] 2nd Line Slave With this option the "PGM OUT" terminal switches to ground after four unsuccessful attempts have been made to the phone number being dialed. The output will stay switched until the panel has hung up. This could be used to switch the panel to a backup set of phone lines.

[E] Kissoff Output With this option the "PGM OUT" terminal switches to ground after the kissoff has been received to complete a "successful" communication to the central station. The terminal switches to ground for 2 seconds.

[F] Remote Operation With this option the "PGM OUT" terminal can be switched remotely using the DLS-1 software (version 5.3 or later).

[31] [32] [33] [34] Split Arming

"Split Arming" feature permits a single control panel to act as two independent alarm systems, each with its own opening and closing schedules, zone assignments and authorized users.

The allowable zone and access code assignments to system A or system B are described below. Typically, zones and access codes are assigned to either Group A or Group B but the PC2550 can be programmed for zones and access codes that are common to both Group A and Group B.

The following four sections are each programmed the same as section [15].

Split System Zone and Access Assignments

[31] Group A Zone Assignment for Zones 1 to 8.

[32] Group B Zone Assignment for Zones 1 to 8.

[33] Group A Access Code Assignment for Codes 1 to 8.

Note: Codes 9 to 16 are always assigned to Group A.

[34] Group B Access Code Assignment for Codes 1 to 8.

Note: Codes 9 to 16 cannot be assigned to Group B.

Common Zones

If a zone (1 through 8 only) is assigned to both Group A and Group B then both Group A and Group B must be armed for that zone to be armed.

Common Access Code

If an access code (1 through 8 only) is assigned to Group A and Group B then that access code will arm and disarm the entire panel.

Armed Status Indications

When the panel is established as a split system, and ONE side only [Group A or B] is armed, the "Armed" indicator will flash and the zone indicators for the group that has been armed will flash.

If both Group A and Group B are armed the "Armed" indicator will be on steadily and the zone lights will not flash.

Zone Bypassing Access Code

When the system is established for split arming, [*] [1] bypassing should be set so that bypassing requires the use of an access code (see section [16]).

Communicator

When the PC2550 is set up for "split arming" and both Group A and Group B systems are reporting to the same telephone number with different account codes, Group A burglar alarms and restorals are programmed as [1] in section [35] to call the 1st phone number only. Light 7 in section [15] must be turned "ON".

Group B burglar alarms and restorals are programmed with a [2] in Section [35] to call the 2nd phone number only. It is necessary to program both the 1st and 2nd phone number locations with the same telephone number.

Notes:

1. The following restrictions apply to split arming applications:

- **The Master Code must be assigned to side A and B.**
- **All codes and zones must be assigned even if not used.**
- **Transmission Delay must not be used.**
- **Home - Away zones must not be used.**
- **Exit Delay Termination must not be used (section [59] light 7 OFF).**
- **Closing Confirmation must not be used (section [59] light 6 OFF).**

2. PGM OUT Option A, Quick Exit, and alarms displayed while armed will only work in a fully armed system.

[35] Communicator Call Direction Options

Programming this section tells the dialer whether to send transmissions to the 1st or 2nd telephone number.

There are four classes of dialer call direction options.

- [0] No transmission for this group
- [1] Call 1st phone number with back up to 2nd number*
- [2] Call 2nd phone number only
- [3] Always call both phone numbers

* Option [1] becomes "Call 1st number only" when light [7] in section [15] is turned on. Do not program backup to 2nd phone number if no 2nd phone number is programmed.

After entering the section number, enter [0], [1], [2] or [3] for each of the following reporting code groups in the order given (total of six digits).

- Zone Group A Alarms and Restorals
- Zone Group B Alarms and Restorals
- Access Codes Group A Openings and Closings
- Access Codes Group B Openings and Closings
- Priority Alarms and Restorals
- Maintenance Alarms and Restorals

Where all reporting codes are to be sent to one telephone number, enter [1] for all of the above groups.

[36] Software Reset EEPROM Memory to Factory Defaults

This section is used to reset the EEPROM memory to the original factory default values. As soon as [36] is entered the EEPROM is reset and the program is restarted as though power has just been applied.

Hardware Reset of EEPROM Memory to Factory Defaults

If the Installer's Code is lost through inadvertent programming, the only means of reprogramming the system is via a hardware reset. If the Installer's Lockout is enabled, there is no way to reprogram the system without entering the correct Installer's Code.

Follow the sequence outlined below to reset the panel to factory default conditions.

1. Power unit down by removing both AC and battery power.
2. Using a short jumper, short pins marked "EEPROM RESET" together.
3. Power PC2550 up.
4. Wait for 10 seconds then remove shorting jumper.
5. The system will have reloaded the EEPROM with the factory default codes.

[37] Through [45] Reserved for Future Use

[46] Downloading Computer Telephone Number

This is the telephone number that the panel would use to call the downloading computer if the CALLBACK feature (section [47]) is enabled or if a user initiated call up is done.

[*][6][+ [Master Code] + [9)].

[47] Modem Configuration

This section is used to enable the Downloading function. If Downloading is enabled then the Downloading access code must be entered (section [27]), and the Panel Identification Code must be entered (section [28]). If Callback is enabled the downloading computer's telephone number must be entered (section [46]).

[1] - [4]

Zone Lights 1 through 4 are used to determine the number of rings before the system will answer an incoming call for downloading. Refer to the Programming Work Sheets for information on programming Zone Lights 1 through 4.

[5] Downloading Answer Enabled/Disabled

On = Downloading Answer Enabled.

The system will answer calls for downloading after the number of rings programmed with Zone Lights 1 through 4.

* Off = Downloading Answer Disabled.

The system will not answer incoming calls. With Downloading Answer disabled, downloading must be performed with the User Call-up or Periodic Downloading functions.

[6] User Call-up Enabled/Disabled

On = User Call-up Enabled.

The user can have the system call the downloading computer by entering the [*][6][Master Code][9] Command. For the User Call-up Command to function, a Downloading Computer Telephone Number and a Panel Identification Code need to be programmed.

* Off = User Call-up Disabled.

[7] Answering Machine Over-ride Enabled/Disabled

On = Answering Machine Over-ride Enabled.

The system may be connected to the same telephone line as an answering machine. To over-ride the answering machine, have the downloading computer call the system and let the telephone line ring only once or twice. After one or two rings, hang up. If the system is called back within the programmed Double Call Delay Time (001 to 255 seconds), the system will answer the next call on the first ring. Refer to the Answering Machine Double Call Timer programming section.

* Off = Answering Machine Over-ride Disabled.

The system will only answer incoming calls after the number of rings programmed with Zone Lights 1 through 4.

[8] Downloading Call Back Enabled/Disabled

On = Downloading Call Back Enabled.

When the system answers the downloading computer's call, both the computer and the system will hang up. The system will then call the Downloading Telephone Number and connect with the computer at that number. If more than one downloading computer is to be used, this function should be disabled.

* Off = Downloading Call Back Disabled.

The downloading computer will have immediate access to the system once the system is identified as a valid system.

* is default condition (see "Downloading").

[48] 5th System Option Code

[1] For Future Use

Note: This zone light must be OFF at all times.

[2] Fire Zone Connection Options

On = Fire Zone Connected to SW AUX.

Smoke detectors on the Fire Zone are powered from the SW AUX terminal. When the [*][4] Command is entered, power will be removed from the smoke detectors to allow them to be reset. When the [*][4] Command is used, the Fire Zone Trouble normally generated from a power supervision relay when power is removed from the smoke detector is not displayed or communicated.

* Off = Fire Zone Not Connected to SW AUX.

[3] Escort Access Code Options

On = Escort Requires Master Code. The Escort voice assisted security control module will only allow remote access to the system if the Master Code is entered.

* Off = Escort Accepts Any Access Code. The Escort voice assisted security control module will allow remote access to the system for any valid access code.

[4] - [6] For Future Use

[7] Test Transmission Options

On = Test Transmission Enabled.

The system will automatically call the programmed telephone numbers and transmit the Test Reporting Code programmed in the Maintenance Alarms Reporting Codes Section at the time programmed in the System Clock Times and at the interval, in days, programmed in the System Times.

* Off = Test Transmission Disabled.

[8] Periodic Downloading Options

On = Periodic Downloading Enabled.

The system will automatically place a call to the downloading computer at the time programmed in the System Clock Times and at the interval, in days, programmed in the System Times. A Downloading Telephone Number must be programmed in the Downloading Computer Telephone Number Section.

* Off = Periodic Downloading Disabled.

* is default condition.

[49] Answering Machine Over-ride Timer

This timer sets the amount of time that can be taken between calls when using the answering machine over-ride (see section [47] light 7 description). Valid entries are from 001 to 249 (in seconds) with a default of 060.

[50] System Test Code and TLM Restoral Code

This section is programmed the same as section [05].

System Test Code

Once a valid code is programmed into the system test code it will be sent to the central station every time that a system test is done ([*][6]+[Master Code]+[8]).

TLM Restoral Code

Once a valid code is programmed into the TLM restoral code it will be sent to the central station every time that the phone line trouble is restored. This will also initiate transmission of all codes unsuccessfully transmitted during the phone line fault.

[52] Access Bypass Mask (Codes 1 to 8)

Use the same method of programming as used in section [19]. In this section it is possible to control which access codes can be used to bypass zones. If the zone light is on that access code can be used to bypass. Zone light 8 in section [16] must be on to enable access bypassing with an access code.

[53] Access Bypass Mask (Codes 9 to 16)

Use the same method of programming as used in section [52].

Note: Zone Lights 1 to 8 represent codes 9 to 16.

[54] TLM Trouble Reporting Code

This reporting code can be transmitted to the monitoring station through a LINKS 1000 Cellular Alarm Transmitter, when a TLM trouble occurs on the regular phone lines. Leave this section blank if there is no LINKS unit connected. See section [05] for programming reporting codes and "Trouble Display [*][2]" for a description of TLM trouble.

[55] LINKS Test Transmission Reporting Code

This reporting code is transmitted to the monitoring station through a LINKS 1000 Cellular Alarm Transmitter periodically for testing the cellular communications. The cellular test transmission occurs at the same time as the regular test transmission. The test transmission time is programmed in sections [20] and [23]. After the cellular test transmission is completed, the periodic test transmission reporting code programmed in section [12] will be transmitted through the regular phone lines.

LINKS 1000 Preamble Codes

They are 4-digit codes used with long distance telephone numbers that are dialled through the LINKS module. These codes are used for programming area codes in cases where a land line telephone number may be a local call, while the cellular telephone number dialled by the LINKS 1000 module is a long distance call.

In the following sections [56], [57] and [58], program 4-digit Preambles for the Phone Numbers. Program all unused digits with hexadecimal "F".

[56] LINKS 1000 Preamble for 1st Phone Number

[57] LINKS 1000 Preamble for 2nd Phone Number

[58] LINKS 1000 Preamble for Downloading Phone Number

[59] 6th System Option Code

[1] PGM Squawk on Exit Options

On = PGM Squawk on Exit Delay.

The PGM output will pulse during the Exit Delay Time. If the Urgency on Exit Delay function described below is enabled, the PGM pulse will be quickened for the last 10 seconds of the Exit Delay.

* Off = No PGM Squawk on Exit Delay.

[2] PGM Squawk on Entry Options

On = PGM Squawk on Entry Delay.

The PGM output will pulse during the Entry Delay Time. If the Urgency on Entry Delay function described below is enabled, the PGM pulse will be quickened for the last 10 seconds of the Entry Delay.

* Off = No PGM Squawk on Entry Delay.

[3] Audible Exit Fault Enabled/Disabled

* On = Audible Exit Fault Enabled.

If a Delay Zone is left open at the end of the Exit Delay, the Entry Delay will begin immediately and the bell or siren will sound a steady alarm. This feature is designed to immediately alert the user that their system has been armed incorrectly.

Off = Audible Exit Fault Disabled.

If a Delay Zone is left open at the end of the Exit Delay, the Entry Delay will begin immediately. If the system is not disarmed before the end of the Entry Delay, an alarm will be generated.

[4] Exit Delay Urgency Tone Option

* On = Audible Exit with Urgency.

The Keypad will sound a pulsing tone during the Exit Delay. During the last 10 seconds of the Exit Delay, the keypad will sound a faster pulsing tone to warn that the Exit Delay is about to expire.

Off = Standard Exit Delay.

The Keypad will be silent for the entire Exit Delay.

[5] Entry Delay Urgency Tone Option

* On = Urgency Applied to Entry Delay.

The Keypad will sound a steady tone during the Entry Delay. During the last 10 seconds of the Entry Delay, the keypad will sound a pulsing tone to warn that the Entry Delay is about to expire.

Off = Standard Entry Delay.

The Keypad will sound a steady tone throughout the Entry Delay time.

[6] Closing Confirmation Enabled/Disabled

On = Closing Confirmation Enabled.

When an Access Code is entered to arm the system, the Exit Delay time will not begin until one of the following events occurs:

- The closing is successfully transmitted to the monitoring station. When the closing is transmitted, the keypad will sound an acknowledgement tone to indicate that the monitoring station has been advised of the closing. The Exit Delay will then begin.

- The closing is not successfully transmitted to the monitoring station. If the closing cannot be transmitted, the Exit Delay will begin and the keypad will sound trouble beeps. Upon disarming, a "Fail to Communicate" (Trouble 5) will be displayed.
- The user may re-enter their Access Code to initiate the Exit Delay.

* Off = Closing Confirmation Disabled.

The Exit Delay time will commence once an access code is entered to arm the system.

Notes:

The following restrictions apply to Closing Confirmation:

- **Split Arming must not be used (sections [31] to [34]).**
- **Auxiliary Delay zones must not be used (section [14]).**
- **Exit Delay Termination must not be used (section [59] light 7 OFF).**

[7] Exit Delay Termination Enabled/Disabled

On = Exit Delay Termination Enabled.

The Exit Delay will be terminated once the Delay Zone for the entry/exit door or area is restored. All audible options associated with the Exit Delay will be silenced when the Exit Delay is terminated.

* Off = Exit Delay Termination Disabled.

The Exit Delay timer will continue to count even after the Delay Zone for the entry/exit door or area is restored. All audible options associated with the Exit Delay will function until the time programmed for the Exit Delay has elapsed.

Notes:

The following restrictions apply to Exit Delay Termination:

- **Split Arming must not be used (sections [31] to [34]).**
- **Closing Confirmation must not be used (section [59] light 6 OFF).**

[8] For Future Use

* is default condition.

Note: PGM output in section [30] must be configured for option 'C' for using options 1 and 2 in this section.

[90] Installer's Lockout Enable

This feature is enabled by entering [90] while in the Installer's Programming mode. A factory default (hardware or software) will not reset the Installer's Code or the download access code once this feature is enabled. A panel that has this lockout feature enabled will give a distinctive audible indication upon power up. This indication is the phone line relay clicking ten times. Make sure that your new Installer's Code has been entered correctly before enabling this feature because there is no way of re-entering the programming mode without the new Installer's Code. Even a reset to the factory default will not change the Installer's Code back to default.

[91] Installer's Lockout Disable

Entering [91] when in the Installer's Programming mode will disable the Installer's Lockout feature.

Note: Panels returned to DSC with the Installer's Lockout feature enabled and no other apparent problems will be subject to an additional service charge.

PROGRAMMING WORK SHEETS

Note: In sections [01] through [13], do not enter any data in sections that are not used.

[01] 1st Phone Number Page 13

--	--	--	--	--	--	--	--	--	--	--	--	--	--	--	--	--	--	--	--	--

- Be sure to enter [#] to end number
- Enter [0] for digit "0" in phone number

[02] 1st Account Code Page 14

--	--	--	--

- For 3 digit code enter [0] for last digit
- Enter [*1*] (HEX A) for digit "0" in account code i.e. Account code 103 would be [1]+[*1*]+[3]+[0].

[03] 2nd Phone Number Page 14

--	--	--	--	--	--	--	--	--	--	--	--	--	--	--	--	--	--	--	--	--

[04] 2nd Account Code Page 14

--	--	--	--

[05] Alarm Reporting Codes Zones 1 to 8 Page 14

		Zone 1 Alarm			Zone 5 Alarm
		Zone 2 Alarm			Zone 6 Alarm
		Zone 3 Alarm			Zone 7 Alarm
		Zone 4 Alarm			Zone 8 Alarm

- For single digit reporting codes, enter [0] as 2nd digit
- Enter [*1*] (HEX A) to transmit a "0". (A "0" digit is 10 pulses.)

[06] Restoral Reporting Codes Zones 1 to 8 Page 14

		Zone 1 Restoral			Zone 5 Restoral
		Zone 2 Restoral			Zone 6 Restoral
		Zone 3 Restoral			Zone 7 Restoral
		Zone 4 Restoral			Zone 8 Restoral

[07] Reporting Codes for Closing (Arming) with Access Codes 1 to 8 Page 15

		Access Code 1			Access Code 6
		Access Code 2			Access Code 7
		Access Code 3			Access Code 8
		Access Code 4			Partial Closing Code
		Access Code 5			

[08] Reporting Codes for Closing (Arming) with Access Codes 9 to 16 Page 15

		Access Code 9			Access Code 14
		Access Code 10			Access Code 15
		Access Code 11			Access Code 16
		Access Code 12			Auto-arm Cancel Code
		Access Code 13			

[09] Reporting Codes for Opening (Disarming) with Access Codes 1 to 8 Page 15

<input type="checkbox"/> <input type="checkbox"/> <input type="checkbox"/>	Access Code 1	<input type="checkbox"/> <input type="checkbox"/> <input type="checkbox"/>	Access Code 5
<input type="checkbox"/> <input type="checkbox"/> <input type="checkbox"/>	Access Code 2	<input type="checkbox"/> <input type="checkbox"/> <input type="checkbox"/>	Access Code 6
<input type="checkbox"/> <input type="checkbox"/> <input type="checkbox"/>	Access Code 3	<input type="checkbox"/> <input type="checkbox"/> <input type="checkbox"/>	Access Code 7
<input type="checkbox"/> <input type="checkbox"/> <input type="checkbox"/>	Access Code 4	<input type="checkbox"/> <input type="checkbox"/> <input type="checkbox"/>	Access Code 8

[10] Reporting Codes for Opening (Disarming) with Access Codes 9 to 16 Page 15

<input type="checkbox"/> <input type="checkbox"/> <input type="checkbox"/>	Access Code 9	<input type="checkbox"/> <input type="checkbox"/> <input type="checkbox"/>	Access Code 14
<input type="checkbox"/> <input type="checkbox"/> <input type="checkbox"/>	Access Code 10	<input type="checkbox"/> <input type="checkbox"/> <input type="checkbox"/>	Access Code 15
<input type="checkbox"/> <input type="checkbox"/> <input type="checkbox"/>	Access Code 11	<input type="checkbox"/> <input type="checkbox"/> <input type="checkbox"/>	Access Code 16
<input type="checkbox"/> <input type="checkbox"/> <input type="checkbox"/>	Access Code 12	<input type="checkbox"/> <input type="checkbox"/> <input type="checkbox"/>	Opening After Alarm Code
<input type="checkbox"/> <input type="checkbox"/> <input type="checkbox"/>	Access Code 13		

[11] Reporting Codes for Priority Alarms and Restorals Page 15

<input type="checkbox"/> <input type="checkbox"/> <input type="checkbox"/>	Fire Zone Alarm
<input type="checkbox"/> <input type="checkbox"/> <input type="checkbox"/>	Auxiliary Input Zone Alarm
<input type="checkbox"/> <input type="checkbox"/> <input type="checkbox"/>	Keypad Panic Alarm [P]
<input type="checkbox"/> <input type="checkbox"/> <input type="checkbox"/>	Keypad Fire Alarm [F]
<input type="checkbox"/> <input type="checkbox"/> <input type="checkbox"/>	Keypad Auxiliary Alarm [A]
<input type="checkbox"/> <input type="checkbox"/> <input type="checkbox"/>	Fire Zone Restoral
<input type="checkbox"/> <input type="checkbox"/> <input type="checkbox"/>	Auxiliary Input Zone Restoral
<input type="checkbox"/> <input type="checkbox"/> <input type="checkbox"/>	Keypad Panic Restoral [P]
<input type="checkbox"/> <input type="checkbox"/> <input type="checkbox"/>	Keypad Fire Restoral [F]
<input type="checkbox"/> <input type="checkbox"/> <input type="checkbox"/>	Keypad Auxiliary Restoral [A]

[12] Reporting Codes for Maintenance Alarms Page 15

<input type="checkbox"/> <input type="checkbox"/> <input type="checkbox"/>	Battery Trouble Alarm
<input type="checkbox"/> <input type="checkbox"/> <input type="checkbox"/>	AC Failure Trouble Alarm
<input type="checkbox"/> <input type="checkbox"/> <input type="checkbox"/>	Day Zone(s) Trouble Alarm
<input type="checkbox"/> <input type="checkbox"/> <input type="checkbox"/>	Bell Circuit Trouble Alarm
<input type="checkbox"/> <input type="checkbox"/> <input type="checkbox"/>	Fire Zone Trouble Alarm
<input type="checkbox"/> <input type="checkbox"/> <input type="checkbox"/>	Auxiliary Power Supply Trouble Alarm
<input type="checkbox"/> <input type="checkbox"/> <input type="checkbox"/>	Periodic Test Transmission

[13] Reporting Codes for Maintenance Restorals Page 16

<input type="checkbox"/> <input type="checkbox"/> <input type="checkbox"/>	Battery Trouble Restoral
<input type="checkbox"/> <input type="checkbox"/> <input type="checkbox"/>	AC Failure Trouble Restoral
<input type="checkbox"/> <input type="checkbox"/> <input type="checkbox"/>	Day Zone(s) Trouble Restoral
<input type="checkbox"/> <input type="checkbox"/> <input type="checkbox"/>	Bell Circuit Trouble Restoral
<input type="checkbox"/> <input type="checkbox"/> <input type="checkbox"/>	Fire Zone Trouble Restoral
<input type="checkbox"/> <input type="checkbox"/> <input type="checkbox"/>	Auxiliary Power Supply Trouble Restoral

[14] Zone Definitions for Zones 1 to 8 Page 16

Note: When defining zones, ASSIGN DELAY ZONES FIRST to zones 1, 2, 3....then assign the other types to the remaining zones in any order desired.

<u>Default</u>			<u>1st Digit</u>	<u>2nd Digit</u>
<input type="checkbox"/> 0 <input type="checkbox"/> 0	<input type="checkbox"/> <input type="checkbox"/> <input type="checkbox"/> <input type="checkbox"/>	Zone 1	0 = Slow, audible	0 = Delay
<input type="checkbox"/> 0 <input type="checkbox"/> 1	<input type="checkbox"/> <input type="checkbox"/> <input type="checkbox"/> <input type="checkbox"/>	Zone 2	1 = Slow, silent	1 = Instant
<input type="checkbox"/> 0 <input type="checkbox"/> 1	<input type="checkbox"/> <input type="checkbox"/> <input type="checkbox"/> <input type="checkbox"/>	Zone 3	2 = Fast, audible	2 = Interior
<input type="checkbox"/> 0 <input type="checkbox"/> 1	<input type="checkbox"/> <input type="checkbox"/> <input type="checkbox"/> <input type="checkbox"/>	Zone 4	3 = Fast, silent	3 = Home-Away
<input type="checkbox"/> 0 <input type="checkbox"/> 2	<input type="checkbox"/> <input type="checkbox"/> <input type="checkbox"/> <input type="checkbox"/>	Zone 5		4 = 24 hr...Bell
<input type="checkbox"/> 0 <input type="checkbox"/> 2	<input type="checkbox"/> <input type="checkbox"/> <input type="checkbox"/> <input type="checkbox"/>	Zone 6		5 = 24 hr...Bell/Buzzer
<input type="checkbox"/> 0 <input type="checkbox"/> 2	<input type="checkbox"/> <input type="checkbox"/> <input type="checkbox"/> <input type="checkbox"/>	Zone 7		6 = 24 hr...Buzzer
<input type="checkbox"/> 0 <input type="checkbox"/> 2	<input type="checkbox"/> <input type="checkbox"/> <input type="checkbox"/> <input type="checkbox"/>	Zone 8		7 = Auxiliary Delay
				8 = Day Zone

[15] 1st System Option Code Page 17

<u>Default</u>			<u>Zone Light On</u>	<u>Zone Light Off</u>
<input type="checkbox"/> Off	<input type="checkbox"/> <input type="checkbox"/> <input type="checkbox"/> <input type="checkbox"/>	Zone Light 1	Communication disabled	Communication enabled
<input type="checkbox"/> Off	<input type="checkbox"/> <input type="checkbox"/> <input type="checkbox"/> <input type="checkbox"/>	Zone Light 2	Restorals on bell timeout	Restorals follow zones
<input type="checkbox"/> Off	<input type="checkbox"/> <input type="checkbox"/> <input type="checkbox"/> <input type="checkbox"/>	Zone Light 3	Alarm display while armed	No alarm display/armed
<input type="checkbox"/> Off	<input type="checkbox"/> <input type="checkbox"/> <input type="checkbox"/> <input type="checkbox"/>	Zone Light 4	DTMF dialing	Pulse dialing
<input type="checkbox"/> Off	<input type="checkbox"/> <input type="checkbox"/> <input type="checkbox"/> <input type="checkbox"/>	Zone Light 5	N/C zones	EOL resistors zones
<input type="checkbox"/> Off	<input type="checkbox"/> <input type="checkbox"/> <input type="checkbox"/> <input type="checkbox"/>	Zone Light 6	Keypad [P]anic audible	Silent
<input type="checkbox"/> On	<input type="checkbox"/> <input type="checkbox"/> <input type="checkbox"/> <input type="checkbox"/>	Zone Light 7	Call 1st phone only	Back up to 2nd phone
<input type="checkbox"/> Off	<input type="checkbox"/> <input type="checkbox"/> <input type="checkbox"/> <input type="checkbox"/>	Zone Light 8	16th code = maid's code	Normal code

[16] 2nd System Option Code Page 17

<u>Default</u>			<u>Zone Light On</u>	<u>Zone Light Off</u>
<input type="checkbox"/> Off	<input type="checkbox"/> <input type="checkbox"/> <input type="checkbox"/> <input type="checkbox"/>	Zone Light 1	Partial Closing Identified	Not Identified
<input type="checkbox"/> Off	<input type="checkbox"/> <input type="checkbox"/> <input type="checkbox"/> <input type="checkbox"/>	Zone Light 2	Master code not changeable	Master code changeable
<input type="checkbox"/> Off	<input type="checkbox"/> <input type="checkbox"/> <input type="checkbox"/> <input type="checkbox"/>	Zone Light 3	Bell squawk enabled	Bell squawk disabled
<input type="checkbox"/> Off	<input type="checkbox"/> <input type="checkbox"/> <input type="checkbox"/> <input type="checkbox"/>	Zone Light 4	PC16 OUT enabled	PC16 OUT disabled
<input type="checkbox"/> Off	<input type="checkbox"/> <input type="checkbox"/> <input type="checkbox"/> <input type="checkbox"/>	Zone Light 5	TLM trouble only	TLM audible when armed
<input type="checkbox"/> Off	<input type="checkbox"/> <input type="checkbox"/> <input type="checkbox"/> <input type="checkbox"/>	Zone Light 6	1400Hz Radionics	2300Hz Radionics
<input type="checkbox"/> Off	<input type="checkbox"/> <input type="checkbox"/> <input type="checkbox"/> <input type="checkbox"/>	Zone Light 7	TLM disabled	TLM enabled
<input type="checkbox"/> Off	<input type="checkbox"/> <input type="checkbox"/> <input type="checkbox"/> <input type="checkbox"/>	Zone Light 8	Access code req'd for bypass	Access code not req'd

[17] 3rd System Option Code Page 18

<u>Default</u>			<u>Zone Light On</u>	<u>Zone Light Off</u>
<input type="checkbox"/> Off	<input type="checkbox"/> <input type="checkbox"/> <input type="checkbox"/> <input type="checkbox"/>	Zone Light 1	No bell during Auto-arm	Bell during Auto-arm
<input type="checkbox"/> Off	<input type="checkbox"/> <input type="checkbox"/> <input type="checkbox"/> <input type="checkbox"/>	Zone Light 2	AC excluded from trouble	AC included
<input type="checkbox"/> Off	<input type="checkbox"/> <input type="checkbox"/> <input type="checkbox"/> <input type="checkbox"/>	Zone Light 3	120 second bypass of zones on power up	Zones active on power up
<input type="checkbox"/> Off	<input type="checkbox"/> <input type="checkbox"/> <input type="checkbox"/> <input type="checkbox"/>	Zone Light 4	Auto-arm cancel req. access code	No code required
<input type="checkbox"/> Off	<input type="checkbox"/> <input type="checkbox"/> <input type="checkbox"/> <input type="checkbox"/>	Zone Light 5	Home-Away with delay	Home-Away as interior
<input type="checkbox"/> Off	<input type="checkbox"/> <input type="checkbox"/> <input type="checkbox"/> <input type="checkbox"/>	Zone Light 6	Force arm on auxiliary delay	Auxiliary delay normal
<input type="checkbox"/> Off	<input type="checkbox"/> <input type="checkbox"/> <input type="checkbox"/> <input type="checkbox"/>	Zone Light 7	TX limit to 24 hr. period	TX limit to armed period
<input type="checkbox"/> Off	<input type="checkbox"/> <input type="checkbox"/> <input type="checkbox"/> <input type="checkbox"/>	Zone Light 8	Show bypass status always	Show bypass status/disarmed

[18] 4th System Option Code Page 19

<u>Default</u>		<u>Zone Light On</u>	<u>Zone Light Off</u>
<input type="checkbox"/> Off	<input type="checkbox"/>	Zone Light 1 Quick exit enabled	Quick exit disabled
<input type="checkbox"/> Off	<input type="checkbox"/>	Zone Light 2 Bell pulses always	Bell pulses upon fire only
<input type="checkbox"/> Off	<input type="checkbox"/>	Zone Light 3 Show bypassed zones/armed	Bypass display normal
<input type="checkbox"/> Off	<input type="checkbox"/>	Zone Light 4 2 min keypad timeout enabled	2 min keypad timeout disabled
<input type="checkbox"/> Off	<input type="checkbox"/>	Zone Light 5 Partial close on auto-arm	No partial close on auto-arm
<input type="checkbox"/> Off	<input type="checkbox"/>	Zone Light 6 Keypad [P]anic silent buzzer	Keypad [P]anic audible buzzer
<input type="checkbox"/> Off	<input type="checkbox"/>	Zone Light 7 [F]ire key disabled	[F]ire key enabled
<input type="checkbox"/> Off	<input type="checkbox"/>	Zone Light 8 Bell shutdown active	Bell shutdown not active

[19] Zones 1 to 8 Bypass Mask Page 20

<u>Default</u>		
<input type="checkbox"/> On	<input type="checkbox"/>	Zone Light 1
<input type="checkbox"/> On	<input type="checkbox"/>	Zone Light 2
<input type="checkbox"/> On	<input type="checkbox"/>	Zone Light 3
<input type="checkbox"/> On	<input type="checkbox"/>	Zone Light 4
<input type="checkbox"/> On	<input type="checkbox"/>	Zone Light 5
<input type="checkbox"/> On	<input type="checkbox"/>	Zone Light 6
<input type="checkbox"/> On	<input type="checkbox"/>	Zone Light 7
<input type="checkbox"/> On	<input type="checkbox"/>	Zone Light 8

Note:
If zone light is on, the zone can be bypassed using the [*] [1] command.

[20] System Times Page 20

<u>Default</u>			Notes:
<input type="text" value="0"/> <input type="text" value="3"/> <input type="text" value="0"/>	<input type="text"/>	Entry Delay Time (in seconds)	1. Valid entries are: 001 to 255. 2. Do not enter "000" - it is not a valid entry.
<input type="text" value="1"/> <input type="text" value="2"/> <input type="text" value="0"/>	<input type="text"/>	Exit Delay Time (in seconds)	
<input type="text" value="0"/> <input type="text" value="0"/> <input type="text" value="4"/>	<input type="text"/>	Bell Cut-off Time (in minutes)	
<input type="text" value="0"/> <input type="text" value="3"/> <input type="text" value="0"/>	<input type="text"/>	AC Failure Transmission Delay (in minutes)	
<input type="text" value="0"/> <input type="text" value="5"/> <input type="text" value="0"/>	<input type="text"/>	Normal Zone Response Time (x 10 ms)	
<input type="text" value="0"/> <input type="text" value="3"/> <input type="text" value="0"/>	<input type="text"/>	Test Transmission/Periodic Download Cycle Time (in days)	

[21] Auxiliary Delay Zone Times Page 20

<u>Default</u>			Note:
<input type="text" value="0"/> <input type="text" value="4"/> <input type="text" value="5"/>	<input type="text"/>	Entry Time (in seconds)	Valid entries are: 001 to 255.
<input type="text" value="1"/> <input type="text" value="8"/> <input type="text" value="0"/>	<input type="text"/>	Exit Time (in seconds)	

[22] Communication Variables Page 20

<u>Default</u>		
<input type="text" value="0"/> <input type="text" value="3"/>	<input type="text"/>	Maximum transmissions until swinger shutdown Enter digits from 01 to 99 for number of transmissions per zone during the period as defined in section [17], 3rd system option code, zone light 7. "00" = Unlimited transmissions per burglary zone (Fire zone never shuts down).
<input type="text" value="0"/> <input type="text" value="0"/>	<input type="text"/>	Delay Before Transmission (Burglary Zones only) Enter digits from 00 to 99 - delay in seconds. "00" = No delay (Fire zone and 24 hr. zones always transmit without delay). Transmission delay as programmed here is for burglary zones only.

[23] System Clock Times Page 21

Default

<input type="text" value="9"/> <input type="text" value="9"/> <input type="text" value="9"/> <input type="text" value="9"/>	<input type="text"/>	Automatic Arming Time of Day	Enter 4 digits from 0 to 9.
<input type="text" value="9"/> <input type="text" value="9"/> <input type="text" value="9"/> <input type="text" value="9"/>	<input type="text"/>	For Future Use	Do not enter [*] or [#].
<input type="text" value="9"/> <input type="text" value="9"/> <input type="text" value="9"/> <input type="text" value="9"/>	<input type="text"/>	Test Transmission Time of Day	

[24] Installer's Code Page 21

Default

<input type="text" value="2"/> <input type="text" value="5"/> <input type="text" value="5"/> <input type="text" value="0"/>	<input type="text"/>		Enter 4 digits from 0 to 9.
			Do not enter [*] or [#].

[25] Master Code (Access Code Number 1) Page 21

Default

<input type="text" value="1"/> <input type="text" value="2"/> <input type="text" value="3"/> <input type="text" value="4"/>	<input type="text"/>		Enter 4 digits from 0 to 9.
			Do not enter [*] or [#].

[26] 2nd Master Code Page 21

Default

<input type="text" value="A"/> <input type="text" value="A"/> <input type="text" value="A"/> <input type="text" value="A"/>	<input type="text"/>		Can be erased by entering [*1111]
			Enter 4 digits from 0 to 9. Do not enter [*] or [#].

[27] Downloading Access Code Page 21

Default

<input type="text" value="2"/> <input type="text" value="5"/> <input type="text" value="2"/> <input type="text" value="5"/>	<input type="text"/>		Enter 4 digits from 0 to 9.
			Do not enter [*] or [#].

[28] Panel Identification Code Page 21

Default

<input type="text" value="2"/> <input type="text" value="5"/> <input type="text" value="0"/> <input type="text" value="1"/>	<input type="text"/>		Enter 4 digits from 0 to 9.
			Do not enter [*] or [#].

[29] Communicator Format Options Page 21

Default

<input type="text" value="1"/>	<input type="checkbox"/>	1st Telephone Number	It is necessary to program a format for each option.
<input type="text" value="1"/>	<input type="checkbox"/>	2nd Telephone Number	

Enter one HEX digit from [0] to [D] for each phone number:

- [0] Silent Knight/Ademco slow, 10 BPS (1400 Hz handshake) 3/1 and 4/1, 4/2 non extended format
- [1] Sescoa, Franklin, DCI, Vertex, 20 BPS (2300 Hz handshake) 3/1 and 4/1, 4/2 non extended format
- [2] Silent Knight fast, 20 BPS (1400 Hz handshake) 3/1 and 4/1, 4/2 non extended format
- [3] Radionics, (2300/1400 Hz* handshake) 3/1, 4/2 non extended format
- [4] Radionics, (2300/1400 Hz* handshake) 3/1, 4/2 non extended with parity format
- [5] Sescoa super speed
- [6], [7] Not used
- [8] Silent Knight/Ademco slow, 10 BPS (1400 Hz handshake) 3/1 extended format
- [9] Sescoa, Franklin, DCI, Vertex, 20 BPS (2300 Hz handshake) 3/1 extended format
- [A] Silent Knight fast, 20 BPS (1400 Hz handshake) 3/1 extended format
- [B] Radionics, (2300/1400 Hz* handshake) 3/1 extended format
- [C] Radionics, (2300/1400 Hz* handshake) 3/1 extended with parity format
- [D] Sescoa super speed (with identified openings/closings)
- [E], [F] Not used

*See section [16] for Radionics Handshake Option

[30] Programmable Input and Output Options Page 22

Default

- | | | | | |
|-----------------------------------|--------------------------|--|---|---|
| <input type="checkbox"/> 2 | <input type="checkbox"/> | Auxiliary Input Zone
(Normally open, momentary closure to "Aux +") | Enter 1, 2, 3 or 4 for options below
[1] Silent 24 hour input
[2] Audible 24 hour input
[3] Momentary key arming
[4] Forced answer | 1, 2, 3 or 4 are the only valid entries |
| <input type="checkbox"/> 2 | <input type="checkbox"/> | Programmable Output
(A 50 mA switch to ground.)
Note: A relay must be used to obtain more current. | Enter 0 to F for options below
[0] LINKS support output
[1] Ground start pulse
[2] Utility output no access code
[3] Utility output any access code
[4] Utility output Group A access code
[5] Utility output Group B access code
[6] Keypad buzzer follow mode
[7] System status (arm/disarm) output
[8] Strobe output (latched alarm output)
[9] Failure to communicate output
[A] TLM and alarm
[B] Courtesy pulse
[C] PGM squawk output
[D] 2nd line slave
[E] Kissoff output
[F] Remote operation (DLS-1 version 5.3 or later) | 0 through F are the only valid entries |

Note: Section [31]...[34] are used for split arming or split reporting only.

[31] Zone Group A Assignment Page 23

Default

- | | | |
|------------------------------------|--------------------------|--------------|
| <input type="checkbox"/> On | <input type="checkbox"/> | Zone Light 1 |
| <input type="checkbox"/> On | <input type="checkbox"/> | Zone Light 2 |
| <input type="checkbox"/> On | <input type="checkbox"/> | Zone Light 3 |
| <input type="checkbox"/> On | <input type="checkbox"/> | Zone Light 4 |
| <input type="checkbox"/> On | <input type="checkbox"/> | Zone Light 5 |
| <input type="checkbox"/> On | <input type="checkbox"/> | Zone Light 6 |
| <input type="checkbox"/> On | <input type="checkbox"/> | Zone Light 7 |
| <input type="checkbox"/> On | <input type="checkbox"/> | Zone Light 8 |

Note: If zone light is on that zone is assigned to Group A.

If light is on in sections [31] and [32], the zone is common to both sides and will only be armed if both sides are armed.

[32] Zone Group B Assignment Page 23

Default

- | | | |
|------------------------------------|--------------------------|--------------|
| <input type="checkbox"/> On | <input type="checkbox"/> | Zone Light 1 |
| <input type="checkbox"/> On | <input type="checkbox"/> | Zone Light 2 |
| <input type="checkbox"/> On | <input type="checkbox"/> | Zone Light 3 |
| <input type="checkbox"/> On | <input type="checkbox"/> | Zone Light 4 |
| <input type="checkbox"/> On | <input type="checkbox"/> | Zone Light 5 |
| <input type="checkbox"/> On | <input type="checkbox"/> | Zone Light 6 |
| <input type="checkbox"/> On | <input type="checkbox"/> | Zone Light 7 |
| <input type="checkbox"/> On | <input type="checkbox"/> | Zone Light 8 |

Note: If zone light is on that zone is assigned to Group B.

If light is on in sections [31] and [32], the zone is common to both sides and will only be armed if both sides are armed.

[33] Access Code Group A Assignment Page 23

Default

On Zone Light 1
 On Zone Light 2
 On Zone Light 3
 On Zone Light 4
 On Zone Light 5
 On Zone Light 6
 On Zone Light 7
 On Zone Light 8

Note: If zone light is on that access code is assigned to Group A.

Access codes 9 through 16 are permanently assigned to Group A.

If zone light is on in sections [33] and [34], the code is common to both sides and will arm or disarm the entire system.

[34] Access Code Group B Assignment Page 23

Default

On Zone Light 1
 On Zone Light 2
 On Zone Light 3
 On Zone Light 4
 On Zone Light 5
 On Zone Light 6
 On Zone Light 7
 On Zone Light 8

Note: If zone light is on, that access code is assigned to Group B.

If light is on in sections [33] and [34], the code is common to both sides and will arm or disarm the entire system.

[35] Communicator Call Direction Options Page 24

Default

1 Zones Group A Alarms and Restorals
 1 Zones Group B Alarms and Restorals
 1 Access Codes Group A Openings and Closings
 1 Access Codes Group B Openings and Closings
 1 Priority Alarms and Restorals
 1 Maintenance Alarms and Restorals

Enter:

[0] No transmissions for this group

[1] Call 1st phone number back up to 2nd (becomes 1st number only, when section [15] item [7] is on)

[2] Call 2nd phone number only

[3] Always call both phone numbers

[36] Software Reset EEPROM Memory to Factory Defaults Page 24

[37] Through [45] Reserved for Future Use Page 24

[49] Answering Machine Over-ride Timer Page 25

Default

 Valid entries are: 001 to 249 (in seconds).

[50] System Test Code and TLM Restoral Code Page 25

 System Test Code

 TLM Restoral Code

Entering a valid reporting code will enable these features.

[52] Access Bypass Mask (Codes 1 to 8) Page 25

Default

 Zone Light 1

 Zone Light 2

 Zone Light 3

 Zone Light 4

 Zone Light 5

 Zone Light 6

 Zone Light 7

 Zone Light 8

Notes:

If zone light is on, code can be used to bypass.

If an access code is not required to bypass zones, this section is irrelevant.

[53] Access Bypass Mask (Codes 9 to 16) Page 25

Default

 Zone Light 1

 Zone Light 2

 Zone Light 3

 Zone Light 4

 Zone Light 5

 Zone Light 6

 Zone Light 7

 Zone Light 8

Notes:

If zone light is on, code can be used to bypass.

If an access code is not required to bypass zones, this section is irrelevant.

[54] TLM Trouble Reporting Code Page 25

Note: For use with LINKS 1000 Cellular Alarm Transmitter only.

 TLM Trouble Reporting Code

[55] LINKS Test Transmission Reporting Code Page 25

Note: For use with LINKS 1000 Cellular Alarm Transmitter only.

 LINKS Test Transmission Reporting Code

Note: In the following sections [56], [57] and [58], program 4-digit Preambles for the Phone Numbers. Program all unused digits with hexadecimal 'F'.

[56] LINKS 1000 Preamble for 1st Phone Number Page 25

[57] LINKS 1000 Preamble for 2nd Phone Number Page 25

[58] LINKS 1000 Preamble for Downloading Phone Number Page 26

[59] 6th System Option Code Page 26

<u>Default</u>	<u>Zone Light On</u>	<u>Zone Light Off</u>
<input type="checkbox"/> Off <input type="checkbox"/> Zone Light 1	PGM Squawk on Exit Delay	No PGM Squawk on Exit Delay
<input type="checkbox"/> Off <input type="checkbox"/> Zone Light 2	PGM Squawk on Entry Delay	No PGM Squawk on Entry Delay
<input type="checkbox"/> On <input type="checkbox"/> Zone Light 3	Audible Exit Fault enabled	Audible Exit Fault disabled
<input type="checkbox"/> On <input type="checkbox"/> Zone Light 4	Audible Exit with Urgency	Standard Exit Delay
<input type="checkbox"/> On <input type="checkbox"/> Zone Light 5	Urgency Applied to Entry Delay	Standard Entry Delay
<input type="checkbox"/> Off <input type="checkbox"/> Zone Light 6	Closing Confirmation enabled	Closing Confirmation disabled
<input type="checkbox"/> Off <input type="checkbox"/> Zone Light 7	Exit Delay Termination enabled	Exit Delay Termination disabled
<input type="checkbox"/> Off <input type="checkbox"/> Zone Light 8	For future use	For future use

Note: PGM output in section [30] must be configured as option 'C' for using options 1 and 2 in this section.

[90] Installer's Lockout Enable Page 26

[91] Installer's Lockout Disable Page 26

JUST FOR THE RECORD

PC2550 Version 1.3

Customer _____

Address _____

Phone _____ **Installation Date** _____

Contact:

#1 Name _____ Phone _____

#2 Name _____ Phone _____

#3 Name _____ Phone _____

Control _____ **Version #** _____ **Account #** _____

Receiver Number _____ **Installer's Code** _____

Zone Type

Protected Area

1 _____

2 _____

3 _____

4 _____

5 _____

6 _____

7 _____

8 _____

Fire Zone _____

Entry Time _____ **Exit Time** _____ **Bell Cut Off** _____

Keypad Zones

• [F] Key On/Off

• [A] Key On/Off

• [P] Key On/Off

Quick Arm On/Off

Quick Exit On/Off

Installer's Lock Out On/Off

Installer's Name _____

HOOKUP DIAGRAMS

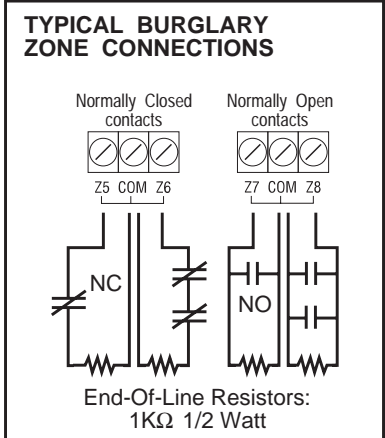
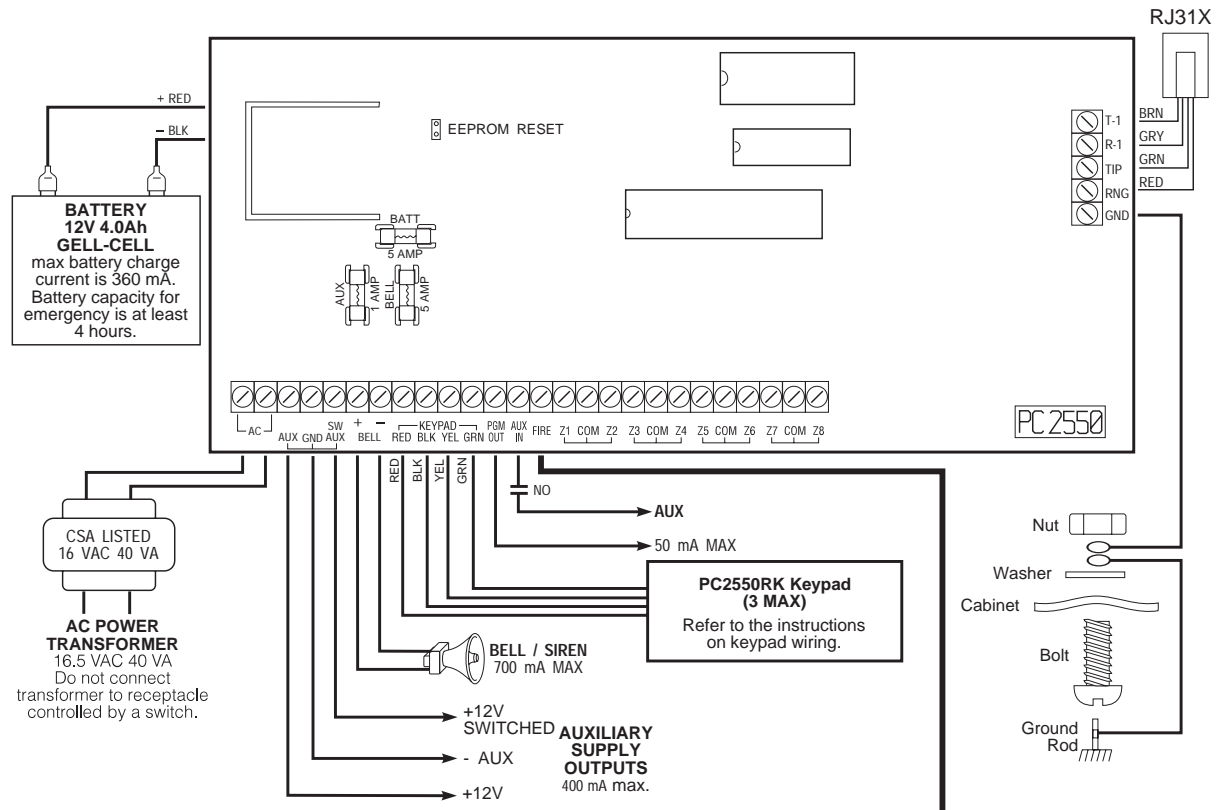

Note: All voltage outputs are rated 12Vdc unregulated.
Temperature Range: 0°C-49°C (32°F-120°F)
Refer to Instruction Manual for complete operating instructions.

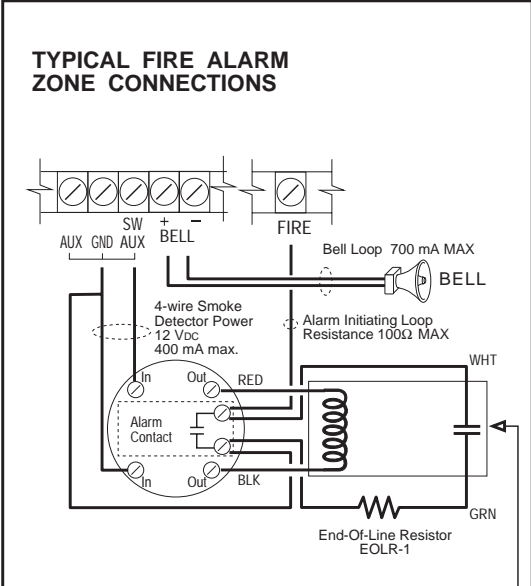

Note: Smoke detector must be 4-wire ULC listed latching type (ESL 446C). To reset smoke detectors - press [*] then hold down key [4] for 2-3 sec.

Smoke Detector Power Supervision Relay (DSC RM-1)
12Vdc 35mA

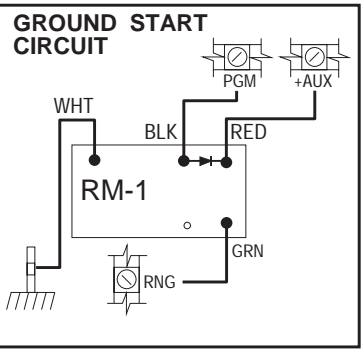
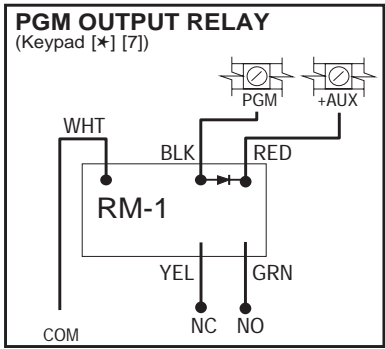

Keypad Hookup

1. Each keypad has four coloured leads: red (RED), black (BLK), yellow (YEL), and green (GRN). Connect the leads to the corresponding terminals on the panel.
2. Up to 3 keypads may be connected in parallel. DO NOT connect multiple keypads on the same zone.
3. The wiring table gives the maximum wire run for various gauges of wire. Wire run lengths are calculated on the maximum current drawn by the keypad (when all lights are ON).
4. For stand-by loading purposes, it is recommended that a current draw of 20 mA per keypad be used. This represents the panel in a disarmed state with two zones in alarm.

Note: If two wires of the same gauge are paralleled, the run length can be doubled. E.g. If eight 22AWG wires (2 RED, 2 BLK, 2 YEL, 2 GRN) are run to the keypad, the run length would double from 540 feet (164.5 m) to 1080 feet (329 m).

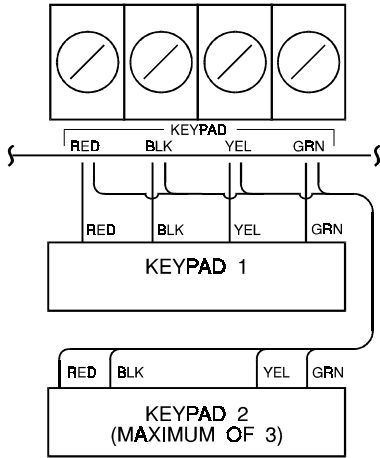

PC2550RK WIRING CHART	
Wire Gauge	Maximum Run Length - Keypad to Panel (feet/meters)
AWG24	330 / 100
AWG22	540 / 164
AWG20	850 / 259
AWG19	1000 / 305
AWG18	1360 / 414

Fire Circuit Hookup

SMOKE DETECTOR POWER LOOP WIRING CHART					
Loop Current mA	Maximum wire run to EOL relay in feet/meters				
	AWG14	AWG16	AWG18	AWG19	AWG22
50	2750/838	1740/530	1090/332	869/264	433/131
100	1375/419	870/265	545/166	435/132	217/66
200	690/210	435/132	270/82	217/66	108/33
300	460/140	290/88	180/55	144/33	144/43
400	345/105	215/65	135/41	108/33	54/16

ALARM INITIATING LOOP WIRING CHART	
Wire Gauge	Maximum Run to End of Line Resistor (feet / meters)
AWG14	15500 / 4724
AWG16	9740 / 2968
AWG18	6120 / 1865
AWG19	4860 / 1481
AWG20	3840 / 1170
AWG21	3060 / 932
AWG22	2420 / 737

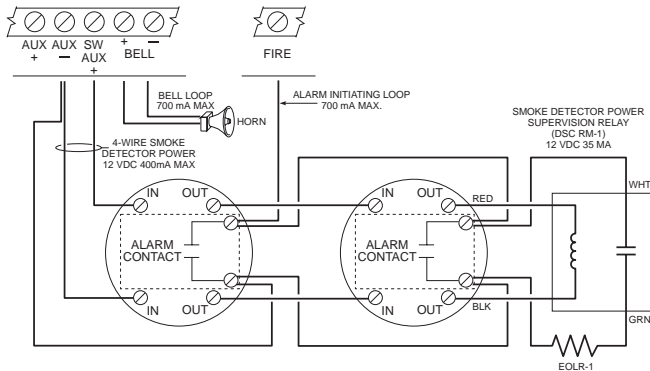

BELL LOOP WIRING CHART					
Bell Current mA	Maximum wire run to EOL resistor in feet/meters				
	AWG14	AWG16	AWG18	AWG19	AWG22
50	2750/838	1740/530	1090/332	869/264	433/131
100	1375/419	870/265	545/166	435/132	217/66
200	690/210	435/132	270/82	217/66	108/33
300	460/140	290/88	180/55	144/33	144/43
400	345/105	215/65	135/41	108/33	54/16
500	275/83	170/52	105/32	86/26	43/13
600	230/70	140/43	90/27	72/22	36/11
700	195/59	125/38	80/24	62/19	30/9

Smoke detector must be latching type (ESL 446C).
To reset smoke detectors, press and hold [*][4].

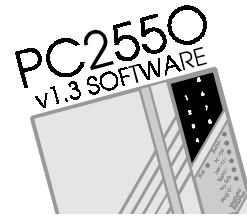

PC2550

Notice of Software Release

PC2550 software version 1.3 has now been released.

Several new features have been added to reduce the possibility of user caused false alarms. And also, additional features have been added to provide further support for the LINKS 1000 and Escort.

These changes are outlined in the following programming sections.

- [17] 3rd System Option Code Page 18
120 second bypass of zones on power up.
- [20] System Times Page 20
System Times now allow more than 4 minutes of Entry or Exit Delay. It provides users additional time when circumstances warrant. The default setting of Exit Delay is 120 seconds.
- [30] Programmable Input and Output Options Page 22
2nd Digit Programmable Output
[C] PGM Squawk Output (for use with options in section [59]).
- [48] 5th System Option Code Page 25
 - Fire Zone on Switched Auxiliary Supply
 - Prevents Fire Alarm Circuit Troubles if [*][4] is used to reset sensors.
 - Escort Accepts Master Code Only
 - Remote access through the Escort requires the Master Code.
- [56] LINKS 1000 Preamble for 1st Telephone Number Page 26
- [57] LINKS 1000 Preamble for 2nd Telephone Number Page 26
- [58] LINKS 1000 Preamble for Downloading Telephone Number Page 26
The LINKS 1000 preambles are 4 digit numbers which are used for programming area codes in cases where the LINKS must call long distance.
- [59] 6th System Option Code Page 26
 - PGM Squawk on Exit Delay - The PGM Output will squawk for the Exit Delay.
 - PGM Squawk on Entry Delay - The PGM Output will squawk for the Entry Delay.
 - Audible Exit Fault - The user is warned that a delay zone was left open when the exit delay expired.
 - Audible Exit Delay with Urgency - The keypad sounds a pulsing tone for the exit delay and sounds a faster pulsing tone for the last 10 seconds.
 - Urgency Applied to Entry Delay - The keypad pulses the steady entry delay tone for the last 10 seconds.
 - Closing Confirmation - The keypad will sound a series of beeps when the closing code has been successfully transmitted.
 - Exit Delay Termination - The exit delay is cancelled when a standard delay zone is restored.

Note: Downloading Software DLS-1 Version 5.3 must be used to upload/download the new PC2550 v1.3 software. Do not attempt to upload/download with the DLS-1 Version 5.2 or earlier software.

DOC NOTICE

NOTICE: The Canadian Department of Communications Label identifies certified equipment. This certification means that the equipment meets certain telecommunications network protective, operational and safety requirements. The Department does not guarantee the equipment will operate to the user's satisfaction.

Before installing this equipment, users should ensure that it is permissible to be connected to the facilities of the local telecommunications company. The equipment must also be installed using an acceptable method of connection. In some cases, the company's inside wiring associated with a single line individual service may be extended by means of certified connector assembly (telephone extension cord). The customer should be aware that compliance with the above conditions may not prevent degradation of service in some situations.

Repairs to certified equipment should be made by an authorized Canadian maintenance facility designated by the supplier. Any repairs or alterations made by the user to this equipment, or equipment malfunctions, may give the telecommunications company cause to request the user to disconnect the equipment.

User should ensure for their own protection that the electrical ground connections of the power utility, telephone lines and internal metallic water pipe system, if present, are connected together. This precaution may be particularly important in rural areas.

CAUTION: Users should not attempt to make such connections themselves, but should contact the appropriate electric inspection authority, or electrician, as appropriate.

The Load Number (LN) assigned to each terminal device denotes the percentage of the total load to be connected to a telephone loop which is used by the device, to prevent overloading. The termination on a loop may consist of any combination of devices subject only to the requirement that the total of the Load Numbers of all the devices does not exceed 100.

The Load Number of this device is 42.

AVIS: L'étiquette du ministère des Communications du Canada identifie le matériel homologué. Cette étiquette certifie que le matériel est conforme à certaines normes de protection, d'exploitation et de sécurité des réseaux de télécommunications. Le Ministère n'assure toutefois pas que le matériel fonctionnera à la satisfaction de l'utilisateur.

Avant d'installer ce matériel, l'utilisateur doit s'assurer qu'il est permis de le raccorder aux installations de l'entreprise locale de télécommunication. Le matériel doit également être installé en suivant une méthode acceptée de raccordement. Dans certains cas, les fils intérieurs de l'entreprise utilisés pour un service individuel à ligne unique peuvent être prolongés au moyen d'un dispositif homologué de raccordement (cordon prolongateur téléphonique interne). L'abonné ne doit pas oublier qu'il est possible que la conformité aux conditions énoncées ci-dessus n'empêche pas la dégradation du service dans certaines situations. Actuellement, les entreprises de télécommunication ne permettent pas que l'on raccorde leur matériel à des jacks d'abonné, sauf dans les cas précis prévus par les tarifs particuliers de ces entreprises.

Les réparations de matériel homologué doivent être effectuées par un centre d'entretien canadien autorisé désigné par le fournisseur. La compagnie de télécommunications peut demander à l'utilisateur de débrancher un appareil à la suite de réparations ou de modifications effectuées par l'utilisateur ou à cause de mauvais fonctionnement.

Pour sa propre protection, l'utilisateur doit s'assurer que tous les fils de mise à la terre de la source d'énergie électrique, des lignes téléphoniques et des canalisations d'eau métalliques, s'il y en a, sont raccordés ensemble. Cette précaution est particulièrement importante dans les régions rurales.

AVERTISSEMENT: L'utilisateur ne doit pas tenter de faire ces raccordements lui-même; il doit avoir recours à un service d'inspection des installations électriques, ou à un électricien, selon le cas.

L'indice de charge (IC) assigné à chaque dispositif terminal indique, pour éviter toute surcharge, le pourcentage de la charge totale qui peut être raccordée à un circuit téléphonique bouclé utilisé par ce dispositif. La terminaison du circuit bouclé peut être constituée de n'importe quelle combinaison de dispositifs, pourvu que la somme des indices de charge de l'ensemble des dispositifs ne dépasse pas 100.

L'indice de charge de cet dispositif est 42.

Limited Warranty

Digital Security Controls Ltd. warrants that for a period of twelve months from the date of purchase, the product shall be free of defects in materials and workmanship under normal use and that in fulfillment of any breach of such warranty, Digital Security Controls Ltd. shall, at its option, repair or replace the defective equipment upon return of the equipment to its repair depot. This warranty applies only to defects in parts and workmanship and not to damage incurred in shipping or handling, or damage due to causes beyond the control of Digital Security Controls Ltd. such as lightning, excessive voltage, mechanical shock, water damage, or damage arising out of abuse, alteration or improper application of the equipment.

The foregoing warranty shall apply only to the original buyer, and is and shall be in lieu of any and all other warranties, whether expressed or implied and of all other obligations or liabilities on the part of Digital Security Controls Ltd. This warranty contains the entire warranty. Digital Security Controls Ltd. neither assumes, nor authorizes any other person purporting to act on its behalf to modify or to change this warranty, nor to assume for it any other warranty or liability concerning this product.

In no event shall Digital Security Controls Ltd. be liable for any direct, indirect or consequential damages, loss of anticipated profits, loss of time or any other losses incurred by the buyer in connection with the purchase, installation or operation or failure of this product.

Warning: Digital Security Controls Ltd. recommends that the entire system be completely tested on a regular basis. However, despite frequent testing, and due to, but not limited to, criminal tampering or electrical disruption, it is possible for this product to fail to perform as expected.

TABLE OF CONTENTS

	Page
Specifications _____	1
Features _____	2
Installation _____	3
Bench Testing _____	3
Mounting Panel _____	3
Hook-up Procedure _____	3
Terminal Connections _____	4
Guidelines for Smoke Detector Location _____	6
Keypad Functions _____	7
Introduction _____	7
Master Code _____	7
2nd Master Code _____	7
Installer's Programming Code _____	7
Arming _____	7
Disarming _____	7
Auto-bypass/Home-Away Arming _____	7
Zone Bypassing _____	7
Trouble Display _____	8
Alarm Memory Display _____	8
Switched Auxiliary Supply Control _____	9
User's Programming Commands _____	9
User's Functions Command _____	9
Installer's Test _____	10
Setting the Clock _____	10
Auto-arm Time of Day _____	10
Quick Arm _____	10
Auto-arm Enable _____	10
Door Chime _____	10
System Test _____	10
User Callup _____	10
Utility Output Command _____	11
Installer's Programming Commands _____	11
"At Home" Arming _____	11
"Quick Arm" Command _____	11
Quick Exit _____	11
Keypad Zones _____	11
Downloading _____	12
Programming Guide _____	13
Introduction _____	13
Binary Data Display _____	13
Reviewing Programmed Data _____	13
[00] Binary Programming _____	13
[01] 1st Phone Number _____	13
[02] 1st Account Code _____	14
[03] 2nd Phone Number _____	14
[04] 2nd Account Code _____	14
Reporting Codes Explanation _____	14

	Page
[05] Alarm Reporting Codes Zones 1 to 8 _____	14
[06] Restoral Reporting Codes Zones 1 to 8 _____	14
[07] Reporting Codes for Closing (Arming) with Access Codes 1 to 8 _____	15
[08] Reporting Codes for Closing (Arming) with Access Codes 9 to 16 _____	15
[09] Reporting Codes for Opening (Disarming) with Access Codes 1 to 8 _____	15
[10] Reporting Codes for Opening (Disarming) with Access Codes 9 to 16 _____	15
[11] Reporting Codes for Priority Alarms and Restorals _____	15
[12] Reporting Codes for Maintenance Alarms _____	15
[13] Reporting Codes for Maintenance Restorals _____	16
[14] Zone Definitions for Zones 1 to 8 _____	16
[15] 1st System Option Code _____	17
[16] 2nd System Option Code _____	17
[17] 3rd System Option Code _____	18
[18] 4th System Option Code _____	19
[19] Zones 1 to 8 Bypass Mask _____	20
[20] System Times _____	20
[21] Auxiliary Delay Zone Times _____	20
[22] Communication Variables _____	20
[23] System Clock Times _____	21
[24] Installer's Code _____	21
[25] Master Code (Access Code Number 1) _____	21
[26] 2nd Master Code _____	21
[27] Downloading Access Code _____	21
[28] Panel Identification Code _____	21
[29] Communicator Format Options _____	21
[30] Programmable Input and Output Options _____	22
[31] [32] [33] [34] Split Arming _____	23
[35] Communicator Call Direction Options _____	24
[36] Software Reset EEPROM Memory to Factory Defaults _____	24
[37] Through [45] Reserved for Future Use _____	24
[46] Downloading Computer Telephone Number _____	24
[47] Modem Configuration _____	24
[48] 5th System Option Code _____	25
[49] Answering Machine Over-ride Timer _____	25
[50] System Test Code and TLM Restoral Code _____	25
[52] Access Bypass Mask (Codes 1 to 8) _____	25
[53] Access Bypass Mask (Codes 9 to 16) _____	25
[54] TLM Trouble Reporting Code _____	25
[55] LINKS Test Transmission Reporting Code _____	25
[56] LINKS 1000 Preamble for 1st Phone Number _____	25
[57] LINKS 1000 Preamble for 2nd Phone Number _____	25
[58] LINKS 1000 Preamble for Downloading Phone Number _____	26
[59] 6th System Option Code _____	26
[90] Installer's Lockout Enable _____	26
[91] Installer's Lockout Disable _____	26
 Programming Work Sheets _____	 27
 Just for the Record _____	 37
 Hookup Diagrams _____	 38